

# **Doheny's**

Pool Supplies **FAST!**

# **Small Sand Filter**

Item #5216

## **INSTALLATION, OPERATION & PARTS**



### **▲ WARNING**

This equipment must be installed and serviced by a qualified technician in accordance with all applicable codes and ordinances. Improper installation can create hazards which could result in property damage, serious injury or death. Improper installation will void the warranty. **The NOTICE label indicates special instructions that are important but not related to hazards.**

### **Notice to Installer**

This manual contains important information about the installation, operation and safe use of this product. Once installation is complete, this manual must be given to the owner / operator of this equipment.

## CHAPTER 1: IMPORTANT SAFETY INSTRUCTIONS

### READ AND FOLLOW ALL INSTRUCTIONS

1. The sand filters are designed to work with water temperature between 32°F and 113°F. The filter should never be operated outside of these temperatures or damage may occur.
2. The installation should be carried out in accordance to the safety instructions of swimming pools and the specific instructions for each facility.
3. The user should make sure that the installation is carried out by qualified authorized persons and that these persons have first carefully read the following instructions. Incorrectly installed equipment may fail, causing severe injury or property damage.
4. The operating safety of the filter is only guaranteed if the installation and operation instructions are correctly followed.
5. To reduce the risk of injury, do not permit children to use this product.
6. Chemical spills and fumes can weaken Swimming Pool or Spa. Corrosion can cause filters and other equipment to fail, resulting in severe injury or property damage. Do not store pool chemicals near your equipment.
7. Any modification of the filter is not authorized. The supplier assumes no liability for the damage and injuries caused by unauthorized replacement parts and accessories.

### Sand Filtration System Working Principle

Incoming water from the piping system is automatically directed by the Multi-Port Valve to the top of the filter bed. As the water is pumped through the filter sand, dirt and debris are trapped by the filter bed, and filtered out. The filtered water is returned from the bottom of the filter tank, through the Multi-Port Valve and back through the piping system.

## CHAPTER 2: PREPARATION BEFORE INSTALL

**▲ WARNING** This product should be installed and serviced only by a qualified professional.

1. Position the filter next to the Swimming Pool or Spa.
2. The filter should be placed on a level concrete slab, very firm ground, or equivalent. Ensure that the ground will not subside, preventing any strain from the attached plumbing.
3. Position the filter so that the piping connections, Multi-Port Valve and winter drain is convenient and accessible for operation, servicing and winterizing.
4. Ensure that the compliance label is facing the front to allow easy identification in the case of service difficulties.

## CHAPTER 3: INSTALLATION INSTRUCTIONS

1. Mount the pump to Sand Filter Support by using the nuts and bolts.

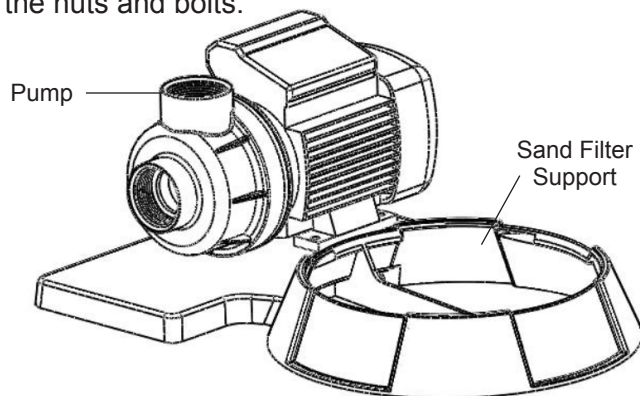

2. Install the Drain Plug Assembly to the Sand Tank.

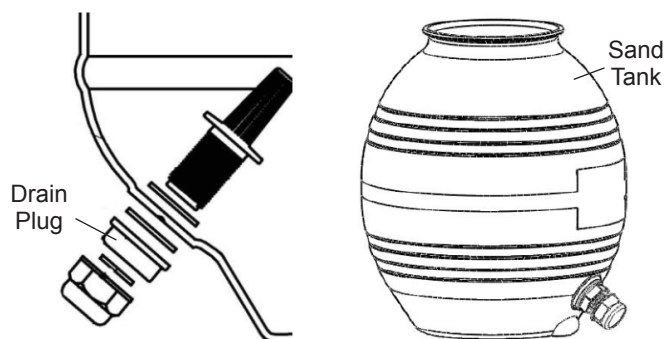

3. Mount Sand Tank to Sand Filter Support. Drain Plug is on the outside.

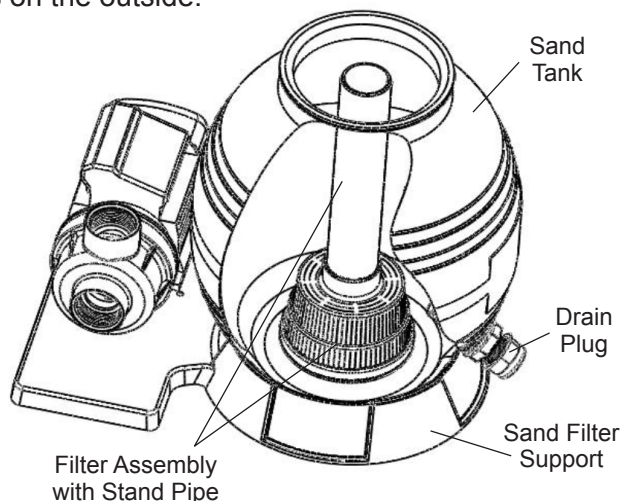

4. Insert the Filter Assembly with Stand Pipe inside the Sand Tank as pictured above. Then place the Stand Pipe Blocker over the Sand Tank's mouth to prevent sand from getting into the Stand Pipe and to keep the Stand Pipe in place. Then pour the Silica Sand (41.8 lbs) into the Sand Tank.

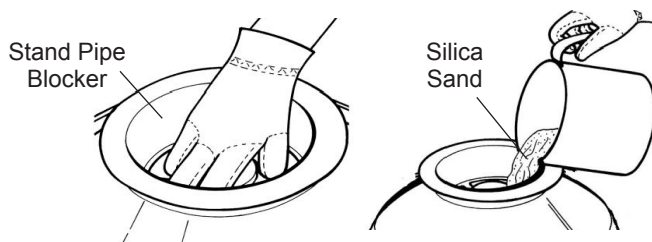

- Remove the Stand Pipe Blocker and clean the Sand Tank neck carefully.

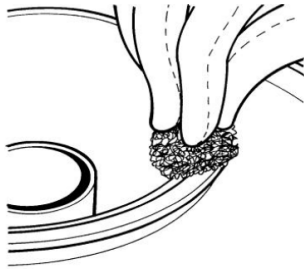

- Connect the Multi-Port Valve to the Sand Tank by using the O-Ring and the Flange Clamp Set. **Note:** the direction of PUMP port on valve needs to face pump out port.

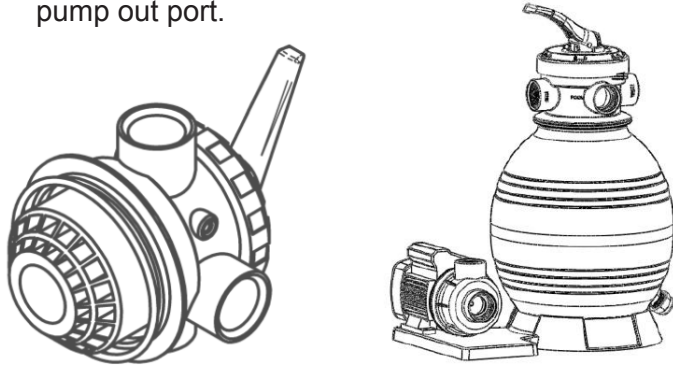

- Connect the Sand Tank to the Pump with Hose, Hose Clamps and Hose Adaptors.



### Plumbing

- Make sure the filter is worked under the work pressure and using a pressure control valve when the system is using a booster pump.
- If the pump position is higher than the water level, it requires to install the back water control valve.
- If the pump position is lower than the water level, it requires installing an isolation valve. It could stop the water return back when people do the general inspection.
- Minimize the length of pipe and the number of fittings to minimize friction loss to ensure maximum efficiency.

- Connect all plumbing to the Multi-Port Valve taking care that all joints are glued or tightened securely to prevent leaking.
- To prevent breakage and damage to the pump and Multi-Port Valve, use only pipe sealants specifically formulated for plastics.
- Ensure solvents are not excessively applied to fittings as this could run into O-Rings and create sealing problems.
- Do not over tighten fittings or adapters.

### CHAPTER 3: MULTI-PORT VALVE OPERATION

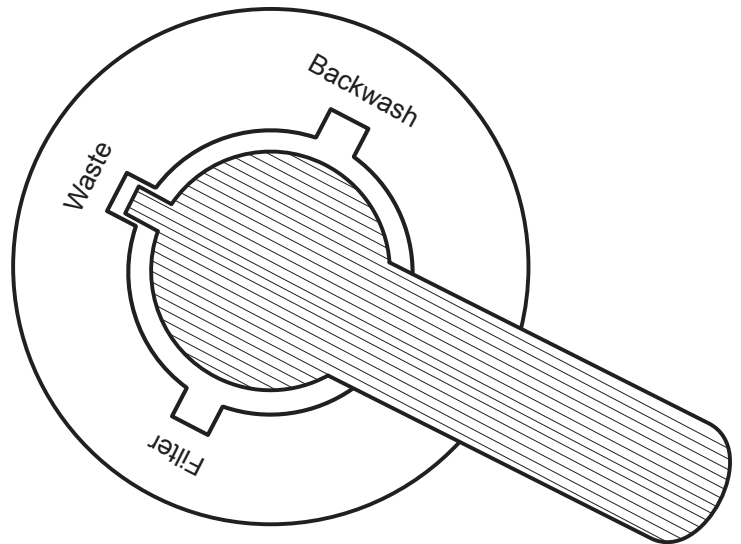

- Filter:** Position for filtering the body of water. Incoming water from the piping system is automatically directed by the Multi-Port Valve to the top of the filter bed. As the water is pumped through the filter sand, dirt and debris are trapped by the filter bed, and filtered out. The filtered water is returned from the bottom of the filter tank, through the Multi-Port Valve and back through the piping system.
- Backwash:** Position for cleaning the filter media. Water flow is reversed by the Multi-Port Valve through the filter bed so that water flow is directed to the bottom of the tank and up through the filter bed, flushing the previously trapped dirt and debris out the waste line.
- Rinse:** Position for flushing the filter system. The water flow is directed by the Multi-Port Valve through the filter bed and out the waste line. This process settles the filter media bed into place and ensures any dirt or debris is rinsed out of the filter, preventing possible return to the Swimming Pool or Spa.
- Waste:** Position for bypassing the filter bed to Waste. The water flow is directed by the Multi-Port Valve straight to the backwash outlet, bypassing the entire filter bed. This Multi-Port Valve position is used to lower the water level or for vacuuming water with high dirt loads.



## CHAPTER 4: INITIAL STARTUP OF FILTER

Recheck that all the connections have been made and are secure, and that the filter media was added to the tank.

1. Depress Multi-Port Valve handle and rotate to the BACKWASH position. **NOTE: To prevent damage to control valve seal, always depress handle before turning.**
2. Switch on the Pump. Open the Inlet Valve allowing the Sand Tank to fill with water. **CAUTION: All suction and discharge valves must be open when starting the pump. Failure to do so could cause severe personal injury and/ or property damage. NOTE: If a pump is installed, switch the pump on and off, instead of closing and opening the Inlet Valve.**
3. Once water flow is steady out the waste line, run the pump for at least one minute. The initial backwashing of the filter is recommended to remove any impurities or fine sand particles in the filter media.
4. Turn the pump off. Set the Multi-Port Valve to the RINSE position. Switch on the Pump. Open the Inlet Valve until water in sight glass is clear - approximately 10 to 15 seconds.
5. Switch off the Pump. Close the Inlet Valve, set the Multi-Port Valve to the FILTER position and Switch on the Pump. Open the Inlet. Your filter is now operating in the normal filter mode.
6. Adjust pool suction and return valves to achieve desired flow. Check the plumbing and filter for water leaks and tighten connections, bolts, and nuts, as required. **NOTE: During initial clean-up of the pool water, it may be necessary to backwash frequently due to the unusually heavy initial dirt load in the water.**
7. Record the pressure gauge reading (start up pressure) during initial operation. After a period of time, the accumulated dirt and debris in the filter causes a resistance to flow, and the flow diminishes. The pressure will start to rise and the flow of water will start diminishing. When the pressure gauge reading is 8-10 PSI higher than the initial "Start up" pressure, it is time to backwash (clean) the filter (see Backwashing). **NOTE: To prevent unnecessary strain on piping system and valving, always shut off the pump before switching filter control valve position. To prevent damage to the pump and filter and for proper operation of they system, clean pump strainer and skimmer baskets regularly.**

## Above Ground Sand Filter Item # 5216

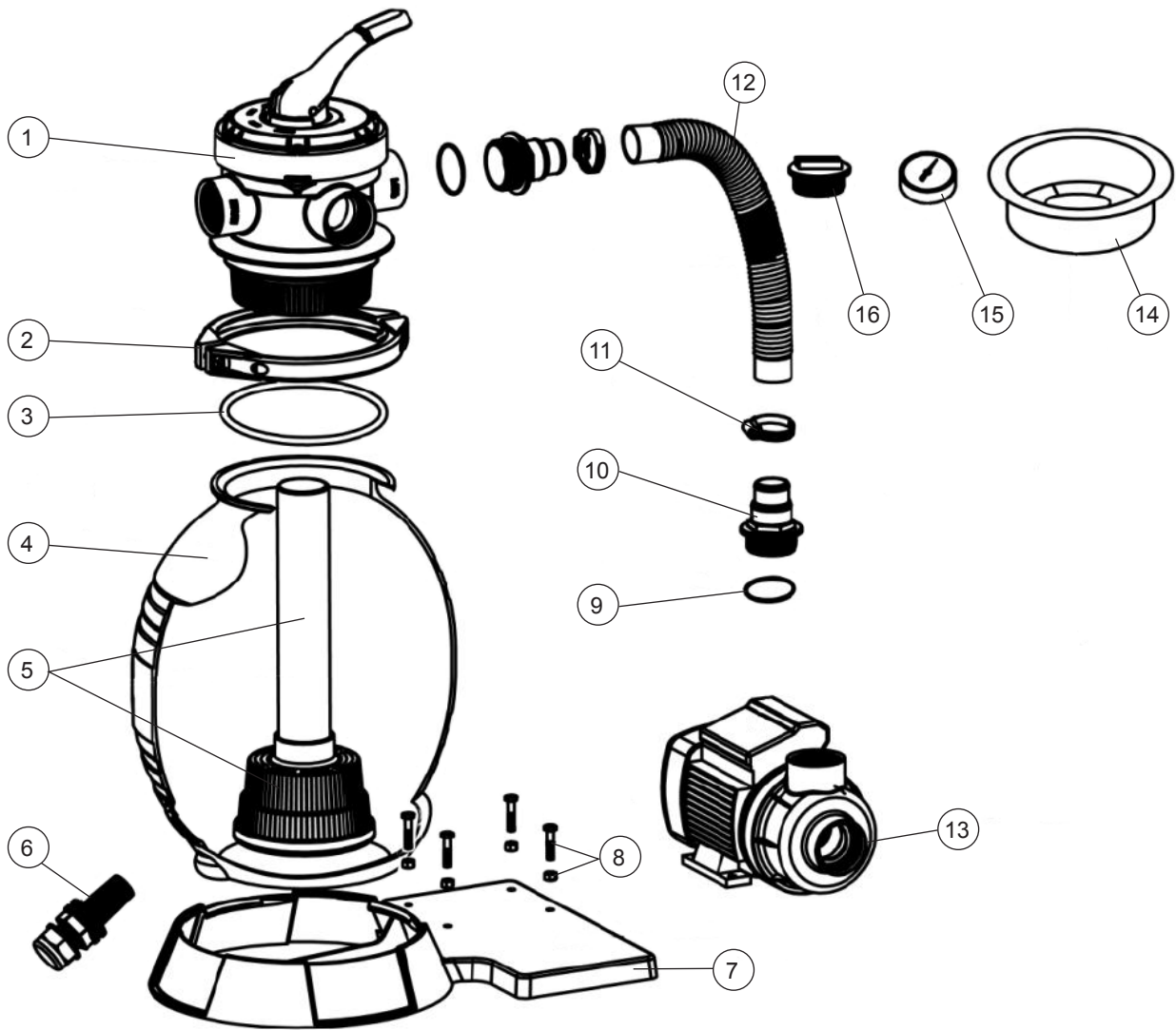

REF No.	PART NUMBER	DESCRIPTION	No. REQ'D
1	647303071001	4-Way Multi-Port Valve	1
2	647303073	Flange Clamp	1
3	65431041080	O-Ring	1
4	647303013931	Filter Tank	1
5	647303074	Filter Assembly with Stand Pipe	1
6	647304073	Drain Plug	1
7	647303012	Sand Filter Support	1
8	647201273	Screw M6X25 and Nut M6	4
9	65431021080	O-Ring	5
10	647303014	Hose Adaptor	5
11	65021004000	Hose Clamp	1
12	65749017011	1-1/4" (32mm) x 45cm Hose	1
13	72714	0.35 HP Pump	1
14	65756006000	Stand Pipe Blocker	1
15	97302	Pressure Gauge	1
16	91215	Plug with O-Ring 1-1/2" MIP	1