



helix2[®]

ASSEMBLY AND INSTALLATION INSTRUCTIONS



WARNING

S.R. SMITH HELIX2 SLIDES ARE MANUFACTURED FOR INSTALLATION AND USE ON RESIDENTIAL INGROUND SWIMMING POOLS ONLY. THE HELIX2 IS NEVER TO BE INSTALLED AND USED ON ABOVEGROUND POOLS, ONGROUND POOLS, HOUSEBOATS, BOAT DOCKS, FLOATING DOCKS OR PLATFORMS OR OTHER BODIES OF WATER SUCH AS LAKES, PONDS, RIVERS, ETC.

SRS AUSTRALIA, PTY LTD
12 Enterprise St
Richlands QLD 4077
Australia
Phone 07 3812 2283 • Fax 07 3812 1187
www.srsmith.com/au

S.R. SMITH, LLC
CORPORATE HEADQUARTERS
P.O. Box 400 • 1017 S.W. Berg Parkway
Canby, Oregon 97013
USA
Phone (503) 266 2231 • Fax (503) 266 4334
www.srsmith.com

TABLE OF CONTENTS

INTRODUCTION.....	3
INSTALLED HELIX2 STRUCTURAL & INSTALLATION CHECKLIST	4
MAINTENANCE INSTRUCTIONS.....	4
ASSEMBLED HELIX2 LAYOUT	5
PARTS LIST.....	6
ASSEMBLY INSTRUCTIONS.....	7
Tools Required.....	7
Gasket Installation.....	7
HELIX2 Assembly	8
ON-DECK MOUNTING INSTRUCTIONS.....	15
SLIDE PLUMBING INSTRUCTIONS.....	16
MANUFACTURER'S PLACEMENT INSTRUCTIONS	17
APPENDIX A.....	A
APPENDIX B.....	B

SLIDE ASSEMBLY AND INSTALLATION VIDEOS AVAILABLE AT
www.youtube.com/srsmithllc

REGISTER YOUR S.R. SMITH PRODUCT AT
www.srsmith.com/en/customer-service/product-registration



Visit srsmith.com for information on the complete line of S.R. Smith pool products.

INTRODUCTION



DANGER – FAILURE TO FOLLOW THESE WARNINGS, INSTRUCTIONS, AND THE OWNER’S MANUAL MAY RESULT IN SERIOUS INJURY OR DEATH.

THE HELIX2 SLIDE IS DESIGNED AND MANUFACTURED FOR INSTALLATION AND USE ON INGROUND SWIMMING POOLS ONLY. DO NOT INSTALL THIS SLIDE ON ABOVE GROUND POOLS, HOUSEBOATS, BOAT DOCKS, FLOATING DOCKS OR PLATFORMS, OR OTHER BODIES OF WATER SUCH AS LAKES, PONDS, RIVERS, ETC. PROPER ASSEMBLY, INSTALLATION, USE, AND SUPERVISION ARE ESSENTIAL FOR PROPER OPERATION AND TO REDUCE THE RISK OF SERIOUS INJURY OR DEATH.

ALL NATIONAL AND LOCAL BUILDING CODES MUST BE FOLLOWED. THIS INCLUDES ANY APPLICABLE REQUIREMENTS FOR SIZE OF CONCRETE FOOTING, OVERALL HEIGHT OF SLIDE, AND BODING OR ELECTRICAL CODES.

CHECK INSIDE ALL BOXES AND PACKAGING MATERIALS FOR PARTS. BEFORE BEGINNING ASSEMBLY, READ ALL INSTRUCTIONS AND IDENTIFY PARTS USING THE FIGURES AND PARTS LISTED IN THIS DOCUMENT. IT IS CRITICAL THAT ALL PARTS BE CAREFULLY INSPECTED BY THE INSTALLER PRIOR TO INSTALLATION TO ENSURE THAT NO DAMAGE OCCURRED IN TRANSIT AND THAT A DAMAGED PART IS NOT USED. PROPER INSTALLATION CANNOT BE OVERSTRESSED, IMPROPER INSTALLATION VOIDS S.R. SMITH’S WARRANTY AND MAY AFFECT THE SAFETY OF THE USER.

INSTALLER MUST GIVE TO SLIDE OWNER: HELIX2 INSTALLATION AND OWNER’S MANUAL, THE WARRANTY CARD, AND ANSWER ALL QUESTIONS REGARDING SAFE AND PROPER USE AND SLIDE MAINTENANCE.

FOR COMPLETE SLIDE SAFETY INFORMATION REFER TO THE OWNER’S MANUAL.

INSTALLED HELIX2 STRUCTURAL & INSTALLATION CHECKLIST

Installer to review with slide owner upon completion of slide installation.

1. Inspect the runway for visible cracks or tears.
2. Inspect the ladder for sharp edges, protrusions, cracks, or tears.
3. Inspect all fasteners to make sure they are fully tightened.
4. Inspect the ladder for rigidity and attachment.
5. Measure the following dimensions and compare with the manufacturer's placement instructions on page 17.
 - Pool water depth at the base of the slide should be at least 3' (0.914 M) deep, and at 4'6" (1.372 M) out from slide exit, should be at least 4'6" (1.372 M) deep.
 - The height of the slide runway exit above the water should be 20" (0.508 M) maximum.
 - The distance between the slide centerline and the edge of other pool equipment should be at least 3'6" (1.067 M).
6. Observe the position of the exit of the slide as shown in FIGURE N, FIGURE O, and FIGURE Q on pages 17 and 18.

MAINTENANCE INSTRUCTIONS

1. When hosing down the deck, hose your HELIX2 to wash away any dust, dirt or other debris, which may have accumulated.
2. Be sure that all connections are secure. Tighten hardware if necessary.
3. All polyethylene parts require little maintenance. Hose and wipe to clean. While cleaning slide, check and see that all nuts and bolts are tight and secure.
4. Inspect the runway for visible cracks or tears, sharp edges and protrusions.
5. Inspect all attachment points for loose or corroded fasteners.
6. Inspect all ladder tread or step-attachment points for evidence of shear, bending yield, or fatigue in the ladder steps, rails, or attachments means. Yield is evidenced by crystallization or fine cracking of the ladder tread and/or surface.
7. Inspect the ladder handrails for rigidity and attachment.

ASSEMBLED HELIX2 LAYOUT

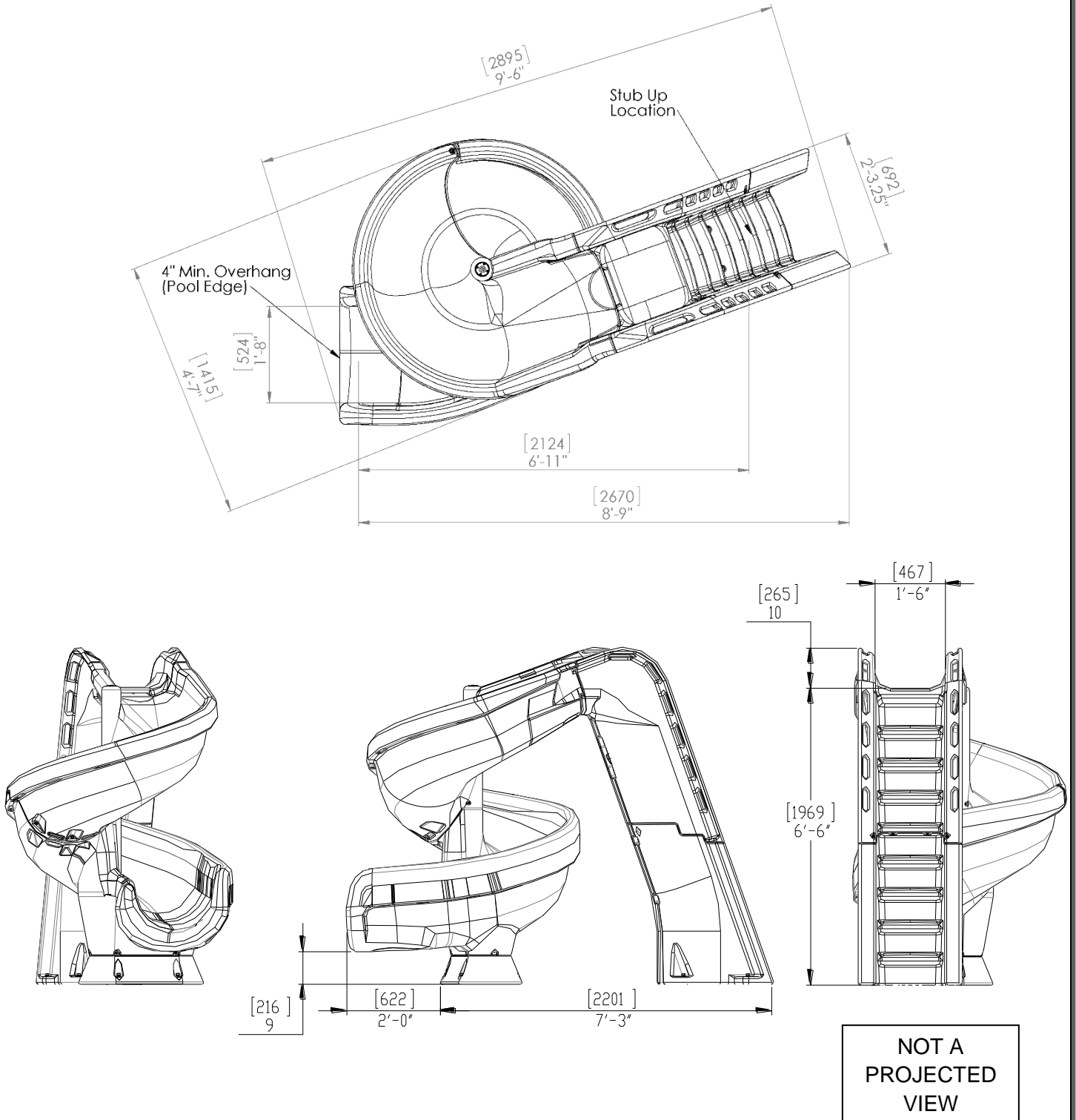

FIGURE A

See Appendices A and B for additional slide layout details.

PARTS LIST

Item No.	Part No.	Description	Qty.
1	5-139	3/8" Hex Nut	9 ea.
2	5-151	3/8" Lock Washer	11 ea.
3	05-14-115	1/2" Lock Washer	8 ea.
4	5-145	3/8" Flat Washer	25 ea.
5	5-246	3/8" x 2-3/4" Carriage Bolt	2 ea.
6	5-247	3/8" x 3" Button Head Cap Screw	4 ea.
7	5-239	3/8" x 2-1/2" Stud	4 ea.
8	5-259	3/8" x 5" Lag Screw	6 ea.
9	5-237	3/8" x 5" Button Head Cap Screw	2 ea.
10	5-248	3/8" x 3.5" Hex Head Cap Screw	2 ea.
11	5-242	#14" x 1" Pan Head Tapping Screw	6 ea.
12	5-241	1/2" x 5" Anchor Stud	8 ea.
13	5-643	3/8"-16 x 2 Hex Head Tap Bolt	1 ea.
14	05-782	1.5" PVC Pipe Strap	2 ea.
15	05-767	1" Pipe Clamp	2 ea.
16	05-770	1" Ball Valve Gray	1 ea.
17	05-784	1" Coupling	1 ea.
18	05-773	Garden Hose Adapter	1 ea.
19	8-532	.5" HIGH X .5" WIDE X 32" LONG RUBBER GASKET	1 ea.
20	05-643	Dark Gray PVC, 1" Slip Pipe Fitting, Female Tee ,SCH80	1 ea.
21	05-660	D.G. 1" PVC Slip Reducer to 1/2" Threaded Female, SCH 80	1 ea.
22	05-667	3/8" to 1/2" barbed 90° elbow fitting	1 ea.
23	05-786-1	1" PVC Flex Hose, 16" long (Not Shown)	1 ea.
24	05-786-2	1" PVC Flex Hose, 68" long (Not Shown)	1 ea.
25	05-661	1" PVC Pipe x 2" Long (Not Shown)	1 ea.
26	5-156	3/8" Acorn Nut	1 ea.
27	05-040-2	1/2" OD X 3/8" ID Polypropylene Tubing (23") (Not Shown)	1 ea.
28	05-652	Valve for .5" OD Tube, Push Fit (Not Shown)	1 ea.
29	8-545A	Kit, Top Runway Gasket (Not Shown)	1 ea.

Visit srsmith.com for hardware kit and replacement part information.

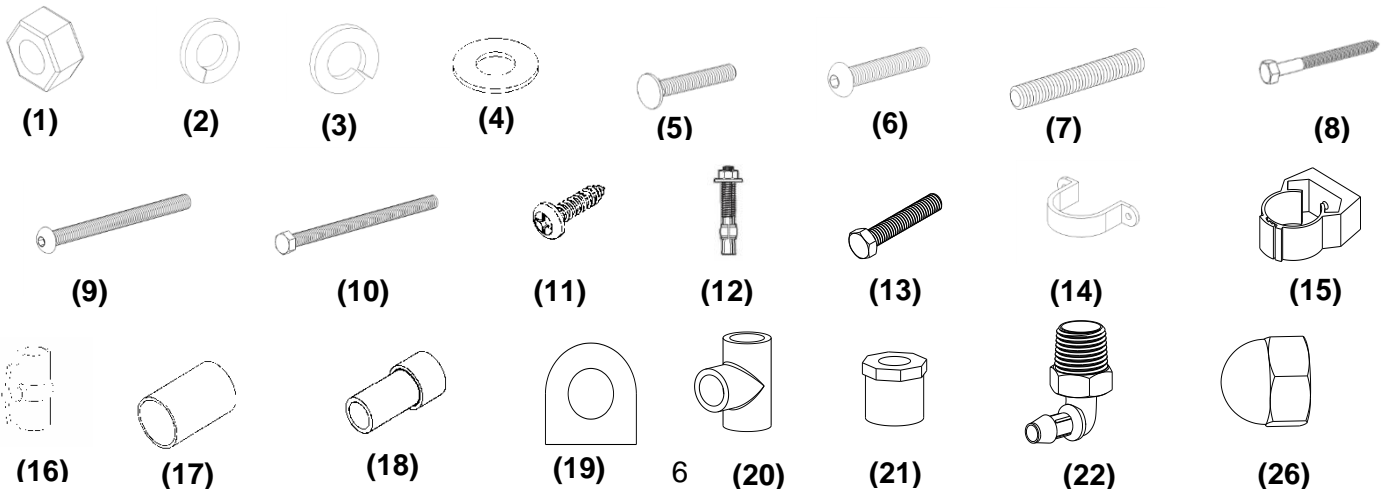

ASSEMBLY INSTRUCTIONS

Tools Required

1. Ratchet handle
2. 9/16" deep socket
3. 9/16" wrench
4. 5/8" wrench
5. 3/4" socket or wrench
6. 7/32" allen wrench
7. Phillips head screwdriver
8. 1/2" (13 mm) concrete drill bit
9. 1/4" (6 mm) drill bit
10. Power drill
11. PVC pipe primer & glue
12. Anti-seize
13. Saw to cut PVC pipe
14. Knife
15. Level
16. Teflon tape (plumbers tape)
17. Silicone sealant
18. Pistol-grip clamp (optional)

NOTE: Use pistol-grip clamps as necessary to align the molded parts.

Gasket Installation

- Most of the gasket material has been installed at the factory, however additional gasket has been provided in case any gasket has fallen off during shipping. If gasket installation is required, follow the instructions below. The gasket on the face of the ladder is not installed in the factory, but detailed instructions are provided in step 8 on page 10.
- Apply gasket (PN 8-532) in the required locations as shown in the figures below.
- Place gasket along the section to determine the length needed.
- Cut gasket to appropriate length, within the width of the runway only, do not include the shoulder.
- Remove backing and adhere gasket to slide.
- All gaskets below are applied as shown in the gasket section detail (see step 8 for further details on installing the ladder gasket, PN 8-531)

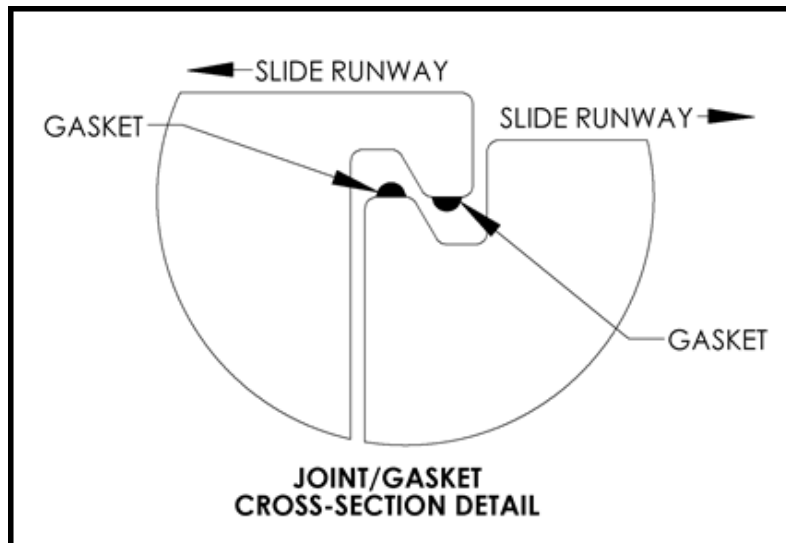

FIGURE B

NOTE:

BE SURE TO APPLY ANTI-SEIZE TO ALL FASTENERS TO PREVENT GALLING.

HELIX2 Assembly

Before getting started:

- To prevent damage to the parts during assembly, it is recommended that cardboard or some other protective barrier is laid down on the ground where the slide is to be assembled.
 - Verify that the gasket material is affixed to the slide parts as shown on page 7
 - During assembly, be sure to apply a thin coat of anti-seize compound to the threads of all fasteners. Anti-seize helps aid in assembly, prevents galling, and improves corrosion resistance.
1. Attach the pedestal part to the runway exit section as shown in FIGURE C by inserting the two lag screws into the holes located in the bottom of the pedestal.
 2. Before inserting the lag bolts into the side of the runway exit part, 1/4" (6 mm) pilot holes must be drilled into the center of each of the recesses, each location is marked with a dimple showing where to drill. The pilot holes should be drilled through both the runway exit section and into the pedestal.

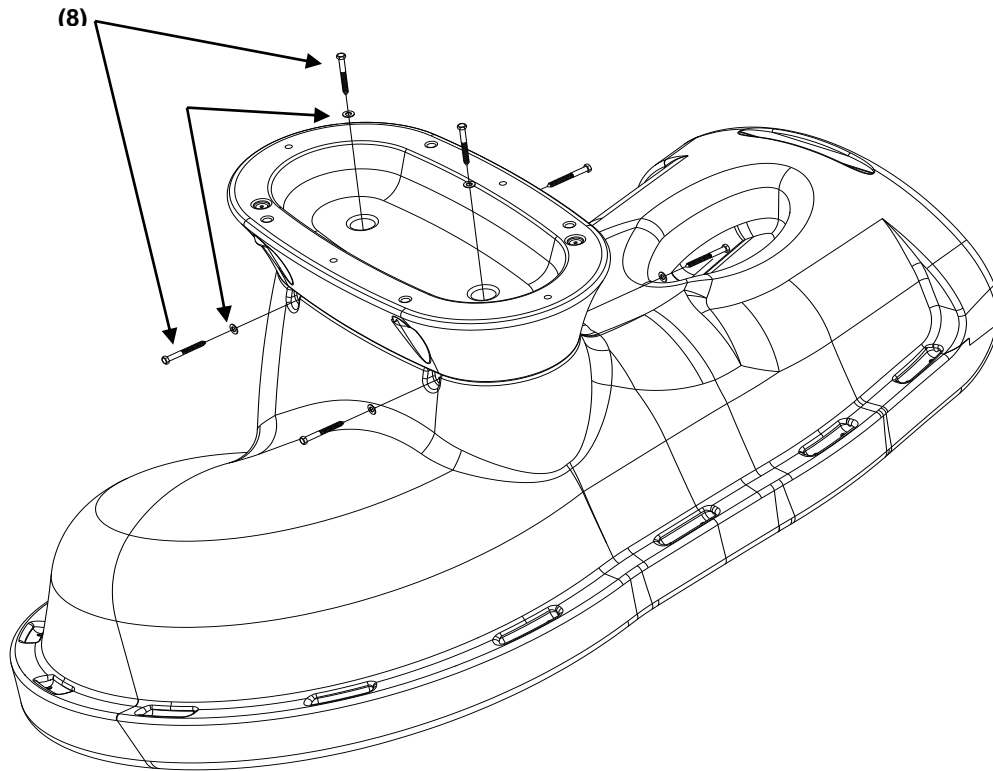
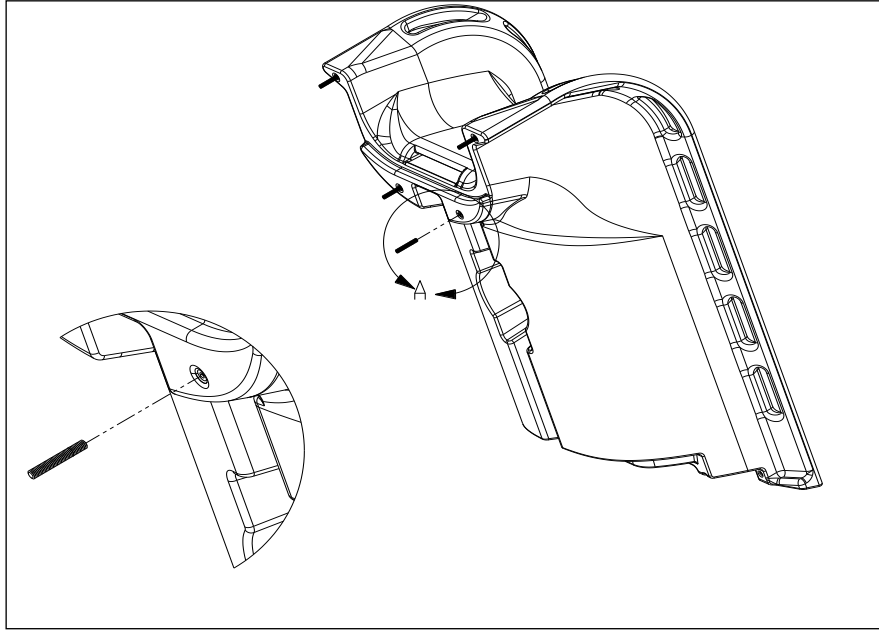

FIGURE C

3. Place the assembled runway exit section and pedestal upright so that the pedestal is resting on the ground. **Notes: It may take more than one person to perform this step. Verify that the gasket material is properly attached before assembling the parts.**
4. Insert the threaded studs into each of the threaded inserts as shown in FIGURE D. The studs should be screwed in by hand until they reach the bottom of the insert. If the studs cannot be threaded in by hand, pliers may be used. Before using pliers, a piece of cloth should be placed over the stud to protect the threads from damage. **Note: Be sure to apply anti-seize to all fasteners to prevent galling.**

FIGURE D



5. Assemble the top ladder section and lower ladder section as shown in FIGURE E. Insert the two button head cap screws into the threaded inserts as shown in FIGURE E. **Do not fully tighten the screws at this point; start the screws into the threaded inserts. Note: Be sure to apply anti-seize to all fasteners to prevent galling.**
6. Insert the button head cap screws into the back side of the ladder as shown in FIGURE F. Tighten the screws until snug. Go back and fully tighten the screws from Step 5. **Note: Be sure to apply anti-seize to all fasteners to prevent galling.**
7. **Insert the two carriage bolts into the steps as shown in FIGURE E. Tighten the nuts onto the carriage bolt until the lock washer is fully compressed. Note: Be sure to apply anti-seize to all fasteners to prevent galling**

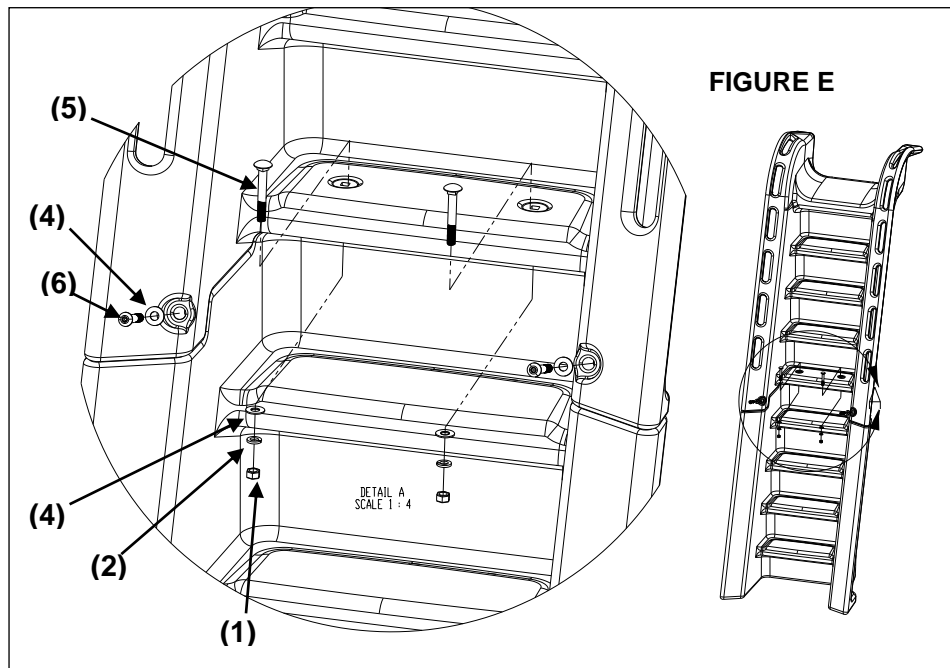

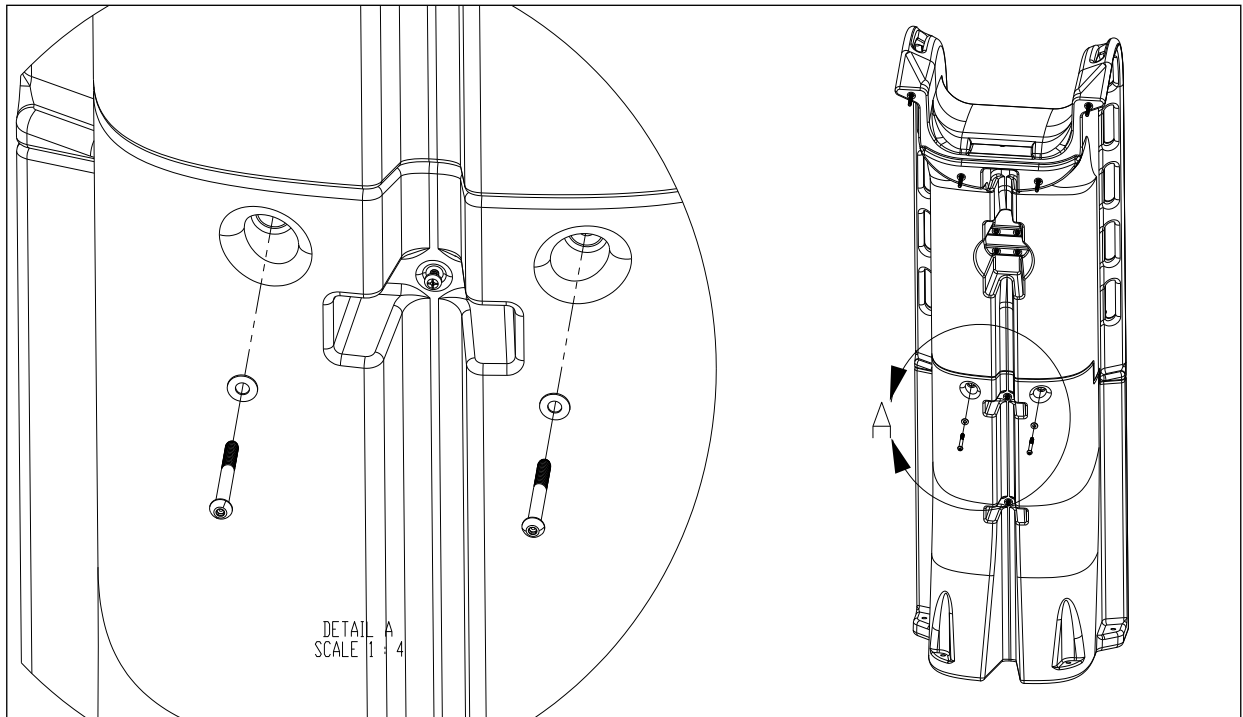
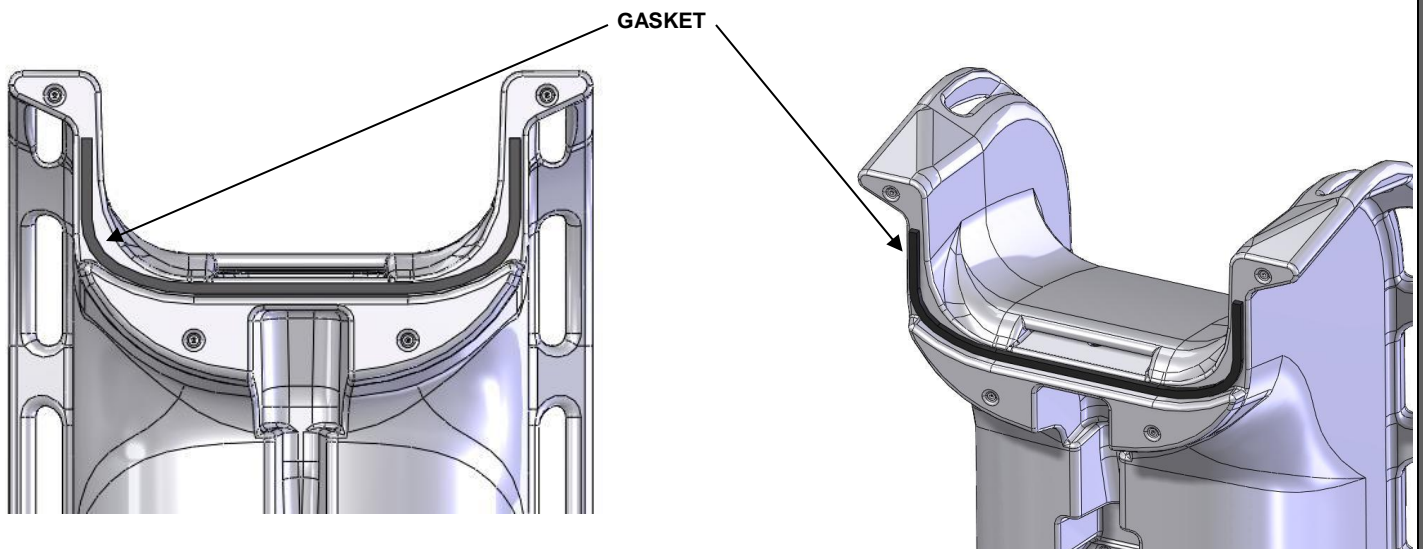
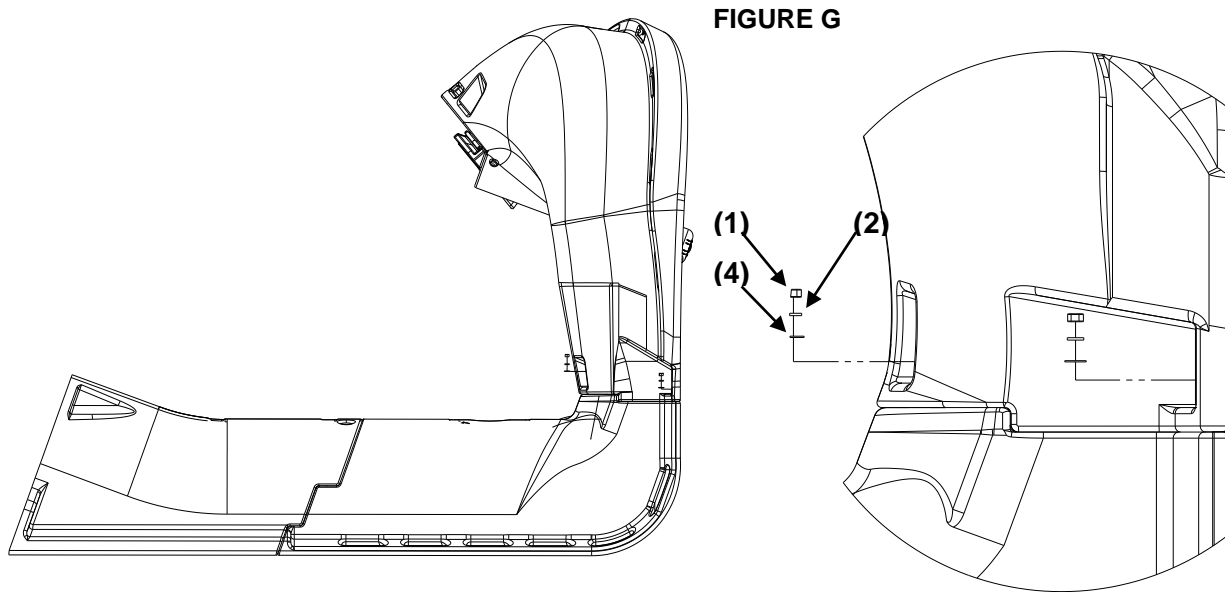

FIGURE F

8. Before applying the gasket to the top of the ladder, be sure that the joint surfaces of the top runway and ladder sections are clean and dry. Unroll the gasket material and hold so that length of the gasket is centered on the center of the ladder joint. With the exposed adhesive side of the gasket facing the ladder joint surface, apply the gasket starting at the center of the part, working outward to the sides. Be sure that the bottom edge of the gasket material is held against the shelf on the ladder part during installation, see reference images below. Do not make too tight of a bend radius with the gasket when transitioning the gasket up the vertical edges of the joint. The transition radius should be as large as possible. Making too tight of a bend radius will cause the gasket to kink and possibly leak. The gasket should be centered on the available space in the vertical area of the joint, see reference images below. Once the gasket is in place, firmly press down on the gasket in all locations to ensure that the gasket has completely adhered to the ladder joint surface. Remove the paper backing on the outward face of the gasket to expose the adhesive. Use caution not to remove the adhesive strip from the gasket when removing the paper backing.



9. Lay the ladder assembly on the ground with the steps facing down as shown in FIGURE G. Lift the upper runway section and align the threaded studs sticking out of the top ladder section with the holes in the upper runway section. Attach the runway to the ladder using the hardware shown in FIGURE G. Tighten until the lock washer is fully compressed.



Notes: *It may take more than one person to perform this step. Verify that the gasket material is properly attached before assembling the parts. Be sure to apply anti-seize to all fasteners to prevent galling.*

10. Apply a .25 inch (6 mm) bead of Silicone sealant (Silicone II or similar) around the base of the cone of the slide's center column. See FIGURE H.

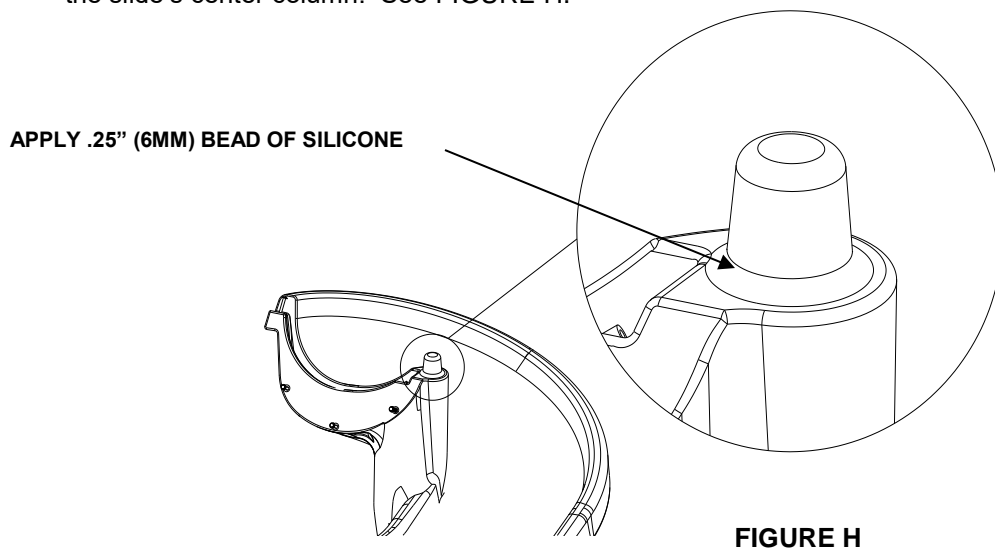

FIGURE H

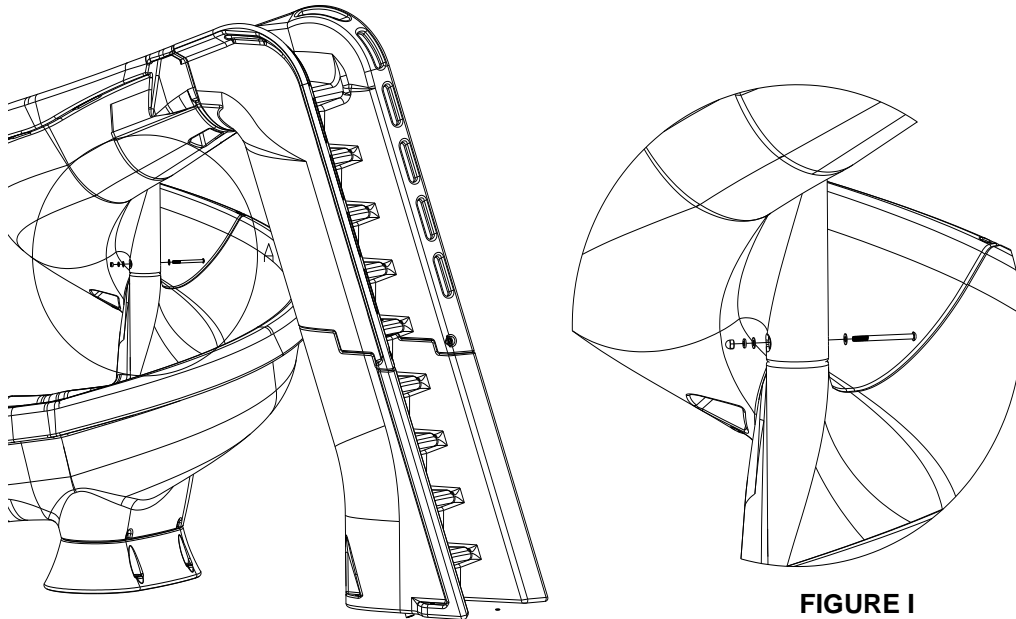

FIGURE I

11. Stand the ladder upright and attach the runway entrance section to the runway exit section using the button head cap screw as shown in FIGURE I through the slides center column. Do not tighten the bolt at this point. **Notes: It may take more than one person to perform this step. Be sure to apply anti-seize to all fasteners to prevent galling.**
12. Finish assembling the two runway sections using the hardware shown in FIGURE J. **Note: Be sure to apply anti-seize to all fasteners to prevent galling.**
 - a. First, the 2" Hex Head Tap Bolt (Item 13) should be started into the threaded insert; do not tighten at this point.
 - b. Install the 5" Button Head screw (Item 9) into the outside rail, and fully tighten.
 - c. Install the hex bolts (Items 10) through the underside of the run way.
 - d. Go through and tighten all of the hardware installed in steps 11 and 12.

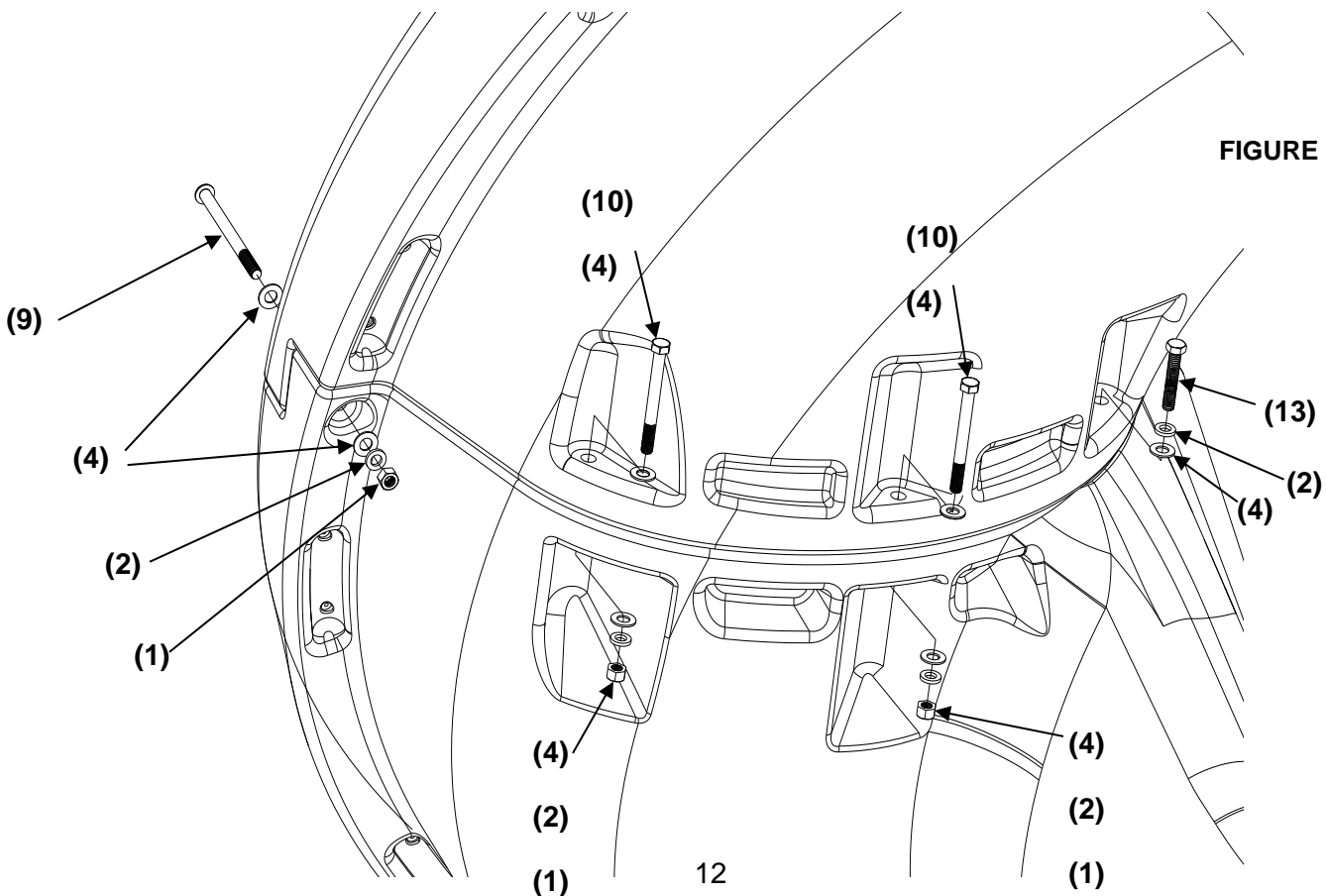

FIGURE J

13. Attach the two *1" Pipe Clamps (15)* with the *#14 Pan Head Screws (11)* as shown in FIGURE K, Detail B. in the recessed area under the slide ladder.
14. Fully assemble the water system components as shown in FIGURE K Detail A without glue to ensure that all components have the correct fit and function before permanently gluing them together.
 - a. The *PVC 1" Slip Pipe "T" Fitting, Female (20)* located directly below the *1" Ball Valve (16)* must be slightly rotated to the right with respect to the handle of the *1" Ball Valve (16)*, as shown in FIGURE K Detail C.
 - b. With the plumbing assembled as shown in FIGURE K Detail C, ensure that the *½" Polypropylene Tubing (27)* is routed behind the *1" PVC Flex Hose (23)* in the recessed area of the ladder and does not interfere with movement of the handle on the *1" Ball Valve (16)*.
 - c. With the components oriented in the correct position, make reference marks on the *1" Ball Valve (16)*, *1" PVC Slip Pipe "T" Fitting, Female (20)* and *1" PVC Pipe 2" long (25)* to ensure correct orientation before gluing.
 - d. When attaching the assembled components with *1.5" Pipe Strap (14)* to the slide ensure that the *½" Polypropylene Tubing (27)* is routed behind *1" PVC Flex Hose (23)*.
15. Once the plumbing fit and function has been verified, remove the plumbing components from the ladder in preparation for final gluing and assembly.
16. Use PVC primer and glue to permanently assemble the parts together as described in Step 14 and shown in FIGURE K. Ensure that The *1" PVC Slip Pipe "T" Fitting, Female (20)*, *1" PVC Pipe 2" long (25)* and *1" Ball Valve (16)* are completely fit together and reference marks are aligned per instruction #14 b.
17. Use plumbers tape (Teflon tape) when permanently assembling the *3/8" to 1/2" barbed 90° elbow fitting (22)* to the *1" PVC Slip Reducer to ½" Threaded Female (21)*.
18. Glue the top end of the *1" PVC Flex Hose 16" long (23)* into the fitting in the ladder.
19. Route the *½" Polypropylene Tubing (27)* behind the *1" PVC Flex Hose 16" long (23)* as shown in FIGURE K Detail C. Connect the *½" Polypropylene Tubing (27)* to the small ball valve attached to the top runway section by pushing the *½" Polypropylene Tubing (27)* into the end of the ball valve firmly as far as it will go. See Figure 13.
20. Secure the assemblies to the recessed area under the slide ladder by attaching the *1.5" PVC Pipe Straps (14)* with the *#14 Pan Head Screws (11)*. See FIGURE K Detail A.
21. Secure the *1" PVC Flex Hose 68" long (24)* in the hose recess under the ladder using the *1" pipe Clamp (15)* firmly pushing the *1" PVC Flex Hose 68" (24)* into the *1" pipe Clamp (15)*.

GLUE TO FITTING
IN LADDER (Step 18)

PUSH INTO SMALL
BALL VALVE (Step 19)

FIGURE K

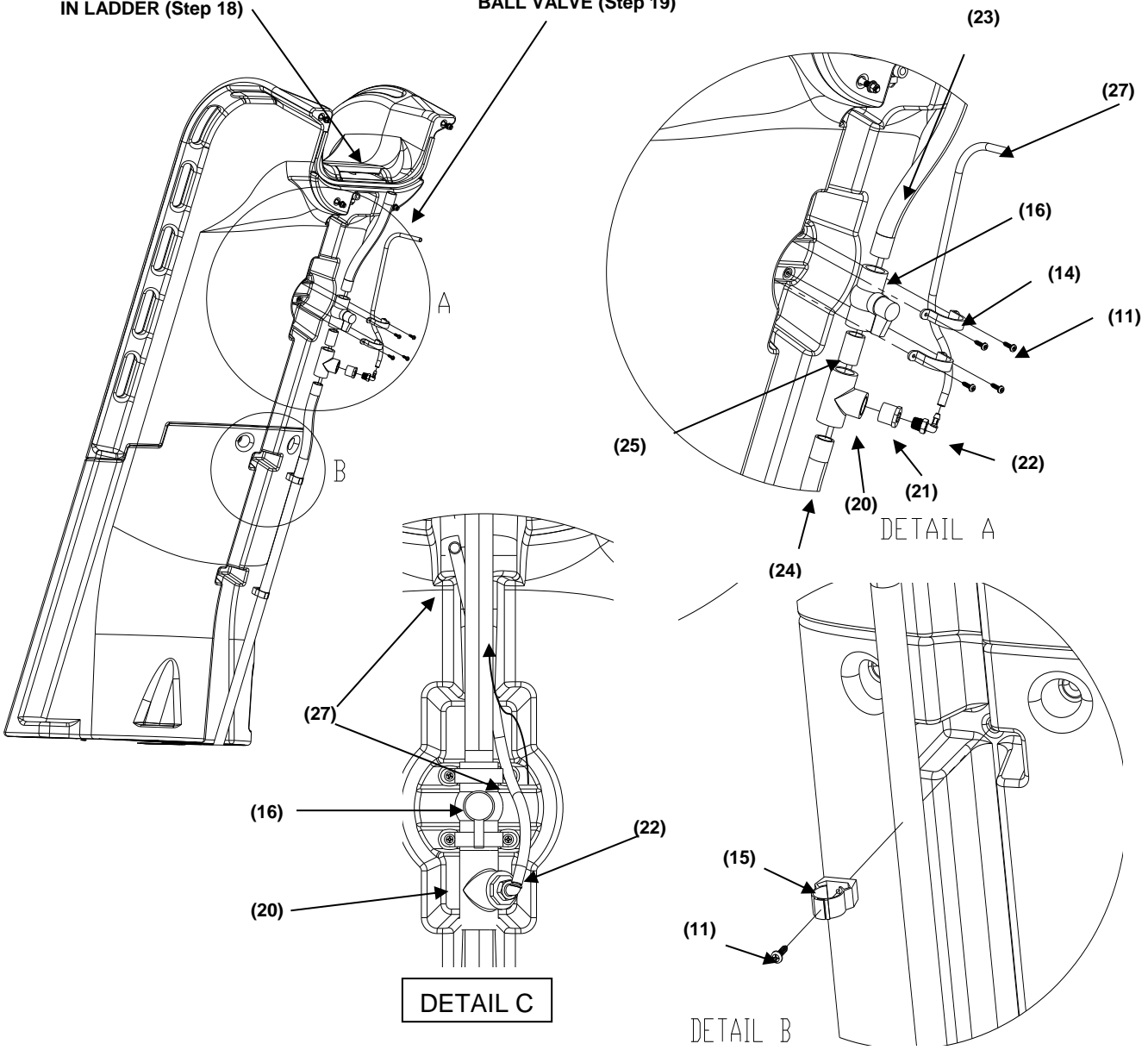

ON-DECK MOUNTING INSTRUCTIONS

1. Place the assembled slide on the deck relative to the pool wall. Ensure that the exit flume clears any coping. Slide may be angled slightly providing all dimensions are maintained as noted in the **Manufacturer's Placement Instructions** noted in the following section.

2. With the slide in its proper location, center punch or otherwise mark through the (8) mounting holes at the bottom of the ladder and pedestal so that a visible mark is apparent on the concrete.

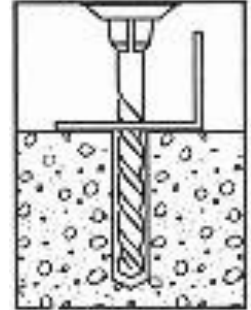

3. Move the assembled slide aside to facilitate drilling of the anchoring holes.

4. Using a power drill and a 1/2" (13 mm) concrete drill bit, drill the holes to a depth of 4" (0.102 M). Use tape or a marking on the drill bit to ensure that the hole for the anchor is drilled to the required depth. Maintain drill hole straight and perpendicular for proper holding strength of anchor stud.

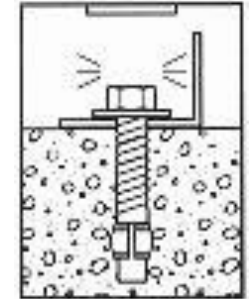

5. Clear the holes of all debris. Assemble anchor with nut and washer so that the top of the nut is flush with the top of the anchor. **Move the slide over the holes before inserting the anchors.** Drive anchor through the slide mounting holes so that nut and washer are flush with the surface material.

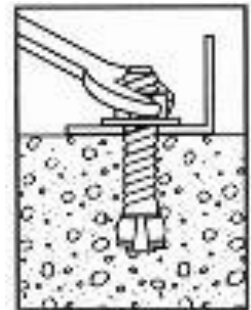

6. Expand anchor by tightening nut 3 to 5 turns. Once anchor is set remove nut and install a lock washer, item # **(3)**, and retighten nut to a torque of 25 ft.-lbs (33.9 N-m).

SLIDE PLUMBING INSTRUCTIONS

FIGURE L

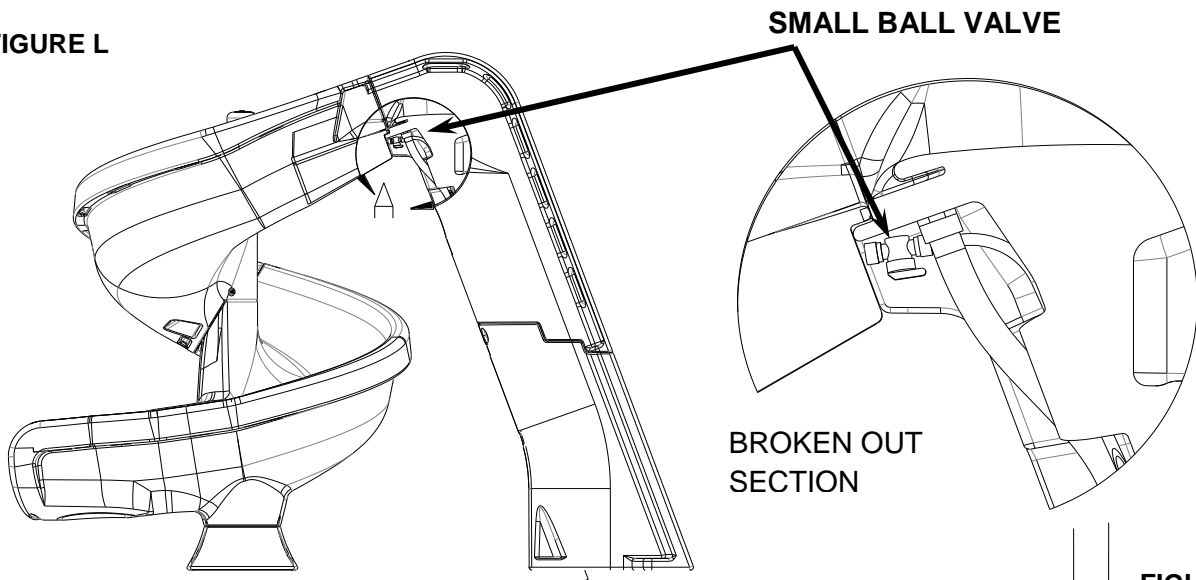

1. The HELIX2™ is designed for a water supply line of 1" pipe. Plumb from pool return line with a 1" PVC pipe "stubbed up" at the deck positioned at the base of the ladder. Refer to FIGURE A on page 5. FIGURE A is for reference only. Assembled slide should be placed in its correct location and the "stub up" location marked and installed before mounting the slide to the deck. "Stub up" should be dark grey PVC to match the plumbing assembly of the slide. **Note: "Stub up" should extend above the deck 18" (457 mm) in height; it will be cut down later in the installation process.**
2. If a garden hose is to be used, a garden hose adapter fitting is included with the slide. Assemble the pieces as shown in FIGURE M and attach to the end of the PVC plumbing assembly at the base of the ladder.
3. Proceed to the following section for **ON-DECK MOUNTING**. After the slide has been mounted to the deck, attach the "stub up" to the plumbing assembly installed in the ladder.
4. The HELIX2™ can handle up to 20 gallons per minute (75 L/min). Water flow to the main water supply is to be regulated using the ball valve (16) near the center of the ladder. The fountain feature can be regulated via the small ball valve just under the top of the ladder. FIGURE L shows the location of the small ball valve.
5. The fountain feature and the main water supply can be either used together or alone.
 - a. To use only the main water supply, shut off the small ball valve. Adjust the large ball valve for the desired water flow.
 - b. To use only the fountain, shut off the large ball valve. Adjust the small ball valve for desired flow.
6. To use both the fountain and the main water supply together, the large ball valve must be partially closed. In general, closing the large ball valve more will increase the flow to the fountain. Adjust the small and large ball valves to obtain the desired flow from each water feature.

FIGURE M

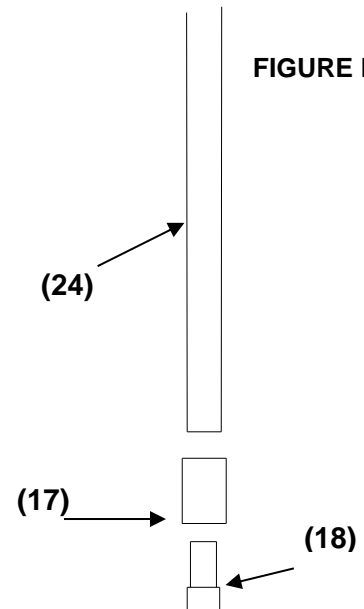

MANUFACTURER'S PLACEMENT INSTRUCTIONS

PROPER ASSEMBLY, INSTALLATION, USE, AND SUPERVISION ARE ESSENTIAL FOR PROPER OPERATION AND TO REDUCE THE RISK OF SERIOUS INJURY.

1. The critical dimensions for placement of the HELIX2 are as shown in FIGURE N and FIGURE O.
 - A. The slide exit runway surface shall not exceed 20" (0.508 M) above the water surface as shown in FIGURE N.
 - B. The slide shall be positioned so that all water flowing off the runway exit drops into the pool. The recommended overhand is 4" (0.102 M).
 - C. The minimum depth of water below the exit lip of the slide shall be 3' (0.914 M) and increase to 4'-6" (1.371 M) at Pt. A, which is a distance of 4'-6" (1.371 M) from the exit lip of the slide as shown in FIGURE N.
 - D. A minimum depth of 4'-6" (1.371 M) shall be maintained at a distance of 9" (2.743 M) along the extended centerline of the slide from Pt. A as shown in FIGURE N.

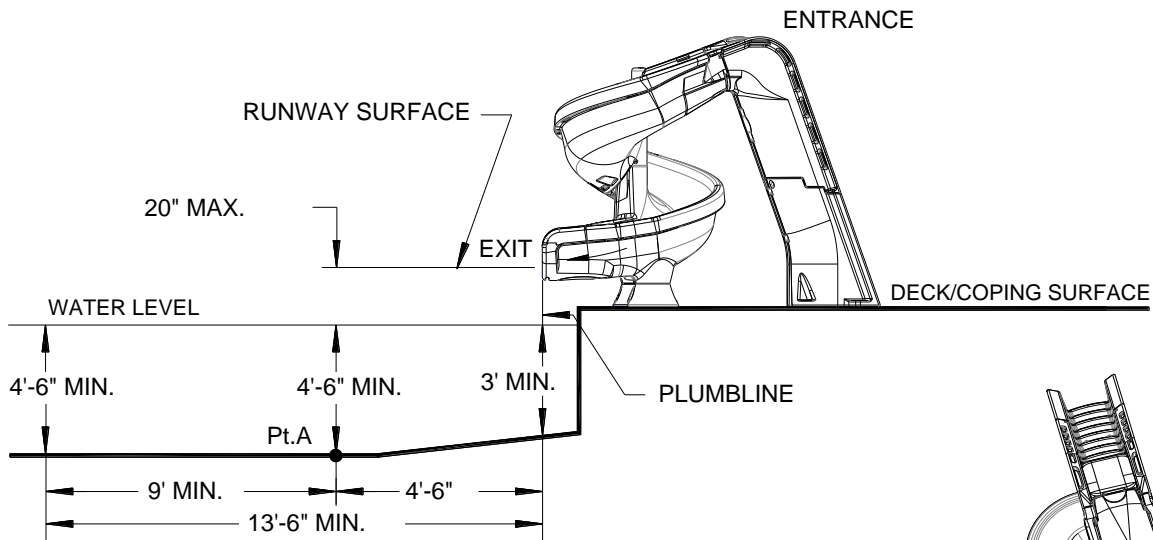

FIGURE N

2. A minimum clearance area in front of the slide shall be maintained at all times as follows:
 - A. The minimum clearance distance on either side of the extended centerline of the slide runway shall not be less than 3'-6" (1.067 M) at a point no less than 2'-6" (0.762 M) from the exit lip of the slide and extending a distance of 13'-6" (4.115 M) in front of the slide as shown in FIGURE O.
 - B. The minimum clearance area in front of a properly installed diving board on an inground swimming pool is a minimum distance of 3'-6" (1.067 M) on either side of the board's centerline as shown in FIGURE P. Pt. C extends a minimum distance of "C" from the tip end of the board as shown in FIGURE P. The width distance "W" on either side of Pt. C is given in TABLE 1 and shown in FIGURE P.

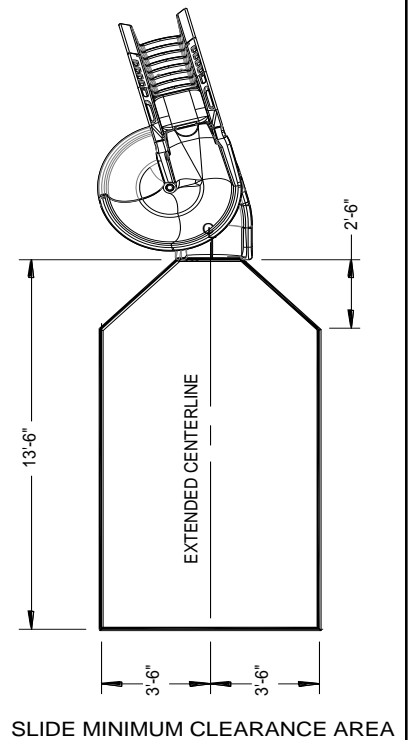

FIGURE O

TABLE 1

Board Minimum Clearance Area		
Pool Type	"C" Dimension	"W" Dimension
I	14' -6" (4.420 M)	5' -0" (1.524 M)
II	14' -6" (4.420 M)	6' -0" (1.829 M)
III	16' -6" (5.029 M)	6' -0" (1.829 M)
IV	18' -6" (5.639 M)	7' -6" (2.286 M)
V	21' -0" (6.401 M)	7' -6" (2.286 M)

See Article 5 contained in ANSI/APSP/ICC-5 2011 STANDARD FOR RESIDENTIAL INGROUND SWIMMING POOLS and refer to FIGURE 3 and Table 1 for Minimum Water Envelope Dimensions AB, BC and Width at Point C.

"C" DIMENSION FOR BOARD = AB + BC
 "W" DIMENSION FOR BOARD = WIDTH AT PT.C

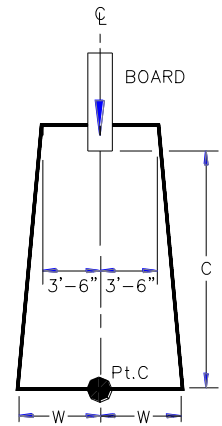

BOARD
MINIMUM CLEARANCE AREA

- C. The minimum clearance area of a slide of diving board shall not intersect any coping or rope and float line as shown in FIGURE Q. The minimum clearance area of a slide or diving board may intersect each other provided that they are not used simultaneously.

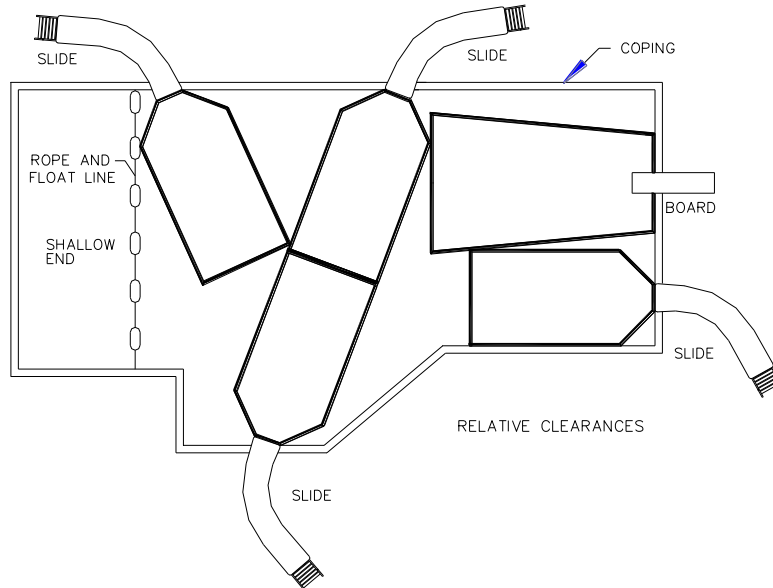
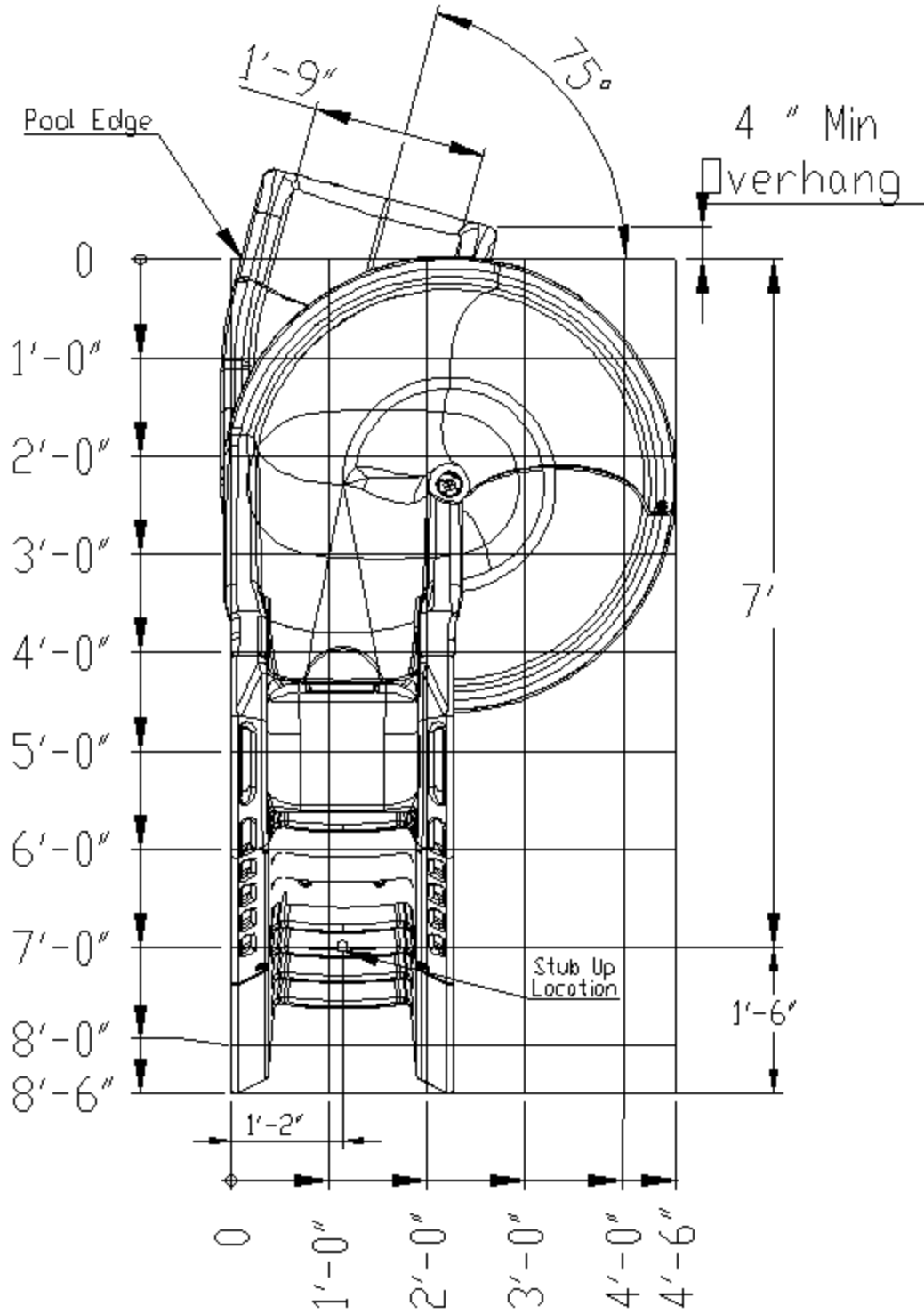

FIGURE Q

APPENDIX A



APPENDIX B

