

Doheny's POOL PROFORCE AG VAR. SPEED.PUMP

Pool Supplies FAST!

Item # 90200

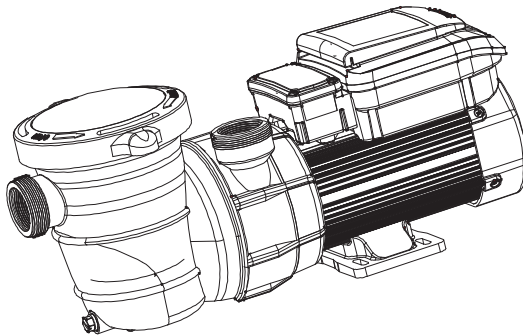

**Read the instruction manual carefully before installation and use.
Please also save it for future reference.**



Water temperature in excess of 100° F (37.7° C) may be hazardous to your health. Prolonged immersion in hot water may induce hyperthermia. Hyperthermia occurs when the internal temperature of the body reaches a level several degrees above normal body temperature of 98.6° F (37° C.). Effects of hyperthermia include: (1) Unawareness of impending danger. (2) Failure to perceive heat. (3) Failure to recognize the need to leave the spa. (4) Physical inability to exit the spa. (5) Fetal damage in pregnant women. (6) Unconsciousness resulting in danger of drowning. The use of alcohol, drugs, or medication can greatly increase the risk of fatal hyperthermia in hot tubs and spas.

To reduce the risk of injury, do not permit children to use or operate this equipment.

When setting up pool water turnovers or flow rates, the operator must consider local codes governing turnover as well as disinfectant feed ratios.

If this pump is intended for use in other than single-family dwellings, a clearly labeled emergency switch shall be provided as part of the installation. The switch shall be readily accessible to the occupants and shall be installed at least 5 feet (1.52 m) away, adjacent to and within sight of this pump.

RISK OF ELECTRICAL SHOCK OR ELECTROCUTION:



PUMPS REQUIRE HIGH VOLTAGE WHICH CAN SHOCK, BURN, OR CAUSE DEATH. Before working on pump, always disconnect power to the pool pump at the circuit breaker before servicing the pump. Failure to do so could result in death or serious injury to service person, pool users or others due to electric shock.

Pumps improperly sized or installed or used in applications other than for which the pump was intended can result in serious personal injury or death. These risks may include but not be limited to electric shock, fire, flooding, suction entrapment or serious injury or property damage caused by a structural failure of the pump or other system component.

Never exceed the maximum stated pump flow rating. Only use a pumping system rated for the corresponding flow. **FAILURE TO DO SO CAN RESULT IN HAIR OR BODY ENTRAPMENT WHICH CAN CAUSE SERIOUS PERSONAL INJURY OR DEATH.** If in doubt about the rating of your system, consult a qualified pool service professional.

Pumps are not a substitute for properly installed and secured pool drain covers. An ANSI/ASME A112.19.8 approved anti-entrapment drain cover must be used for each drain. Pools and spas should utilize a minimum of two drains per pump. Regularly inspect all covers for cracks, damage and advanced weathering. If a cover becomes loose, cracked, damaged, broken or is missing, close the pool or spa immediately, shut off the pump, post a notice and keep the pool or spa closed until an appropriate VGB 2008 certified cover is properly installed. Covers deteriorate over time due to exposure to sunlight and pool chemicals. This cover must be replaced within seven (7) years from installation (or earlier if the cover becomes damaged in any way).

WARNINGS AND IMPORTANT SAFETY PRECAUTIONS

⚠ DANGER SUCTION ENTRAPMENT HAZARD



Hair Entanglement – When the hair tangles or knots in the drain cover, trapping the swimmer underwater. This hazard is present when the flow rating of the cover is too small for the pump or pumps.

Limb Entrapment – When a limb is sucked or inserted into an opening resulting in a mechanical bind or swelling. This hazard is present when a drain cover is missing, broken, loose, cracked or not properly secured.

Body Entrapment – When a portion of the body is held against the drain cover trapping the swimmer underwater. This hazard is present when the drain cover is missing, broken or the cover flow rating is not high enough for the pump or pumps.

Evisceration/Disembowelment – When a person sits on an open pool (particularly a child wading pool) or spa outlet and suction is applied directly to the intestines, causing severe intestinal damage. This hazard is present when the drain cover is missing, loose, cracked, or not properly secured.

Mechanical Entrapment – When jewelry, swimsuit, hair decorations, finger, toe or knuckle is caught in an opening of an outlet or drain cover. This hazard is present when the drain cover is missing, broken, loose, cracked, or not properly secured.

GENERAL SAFETY RULES

1. The products mentioned in this manual are specially designed for the pre-filtering and re-circulation of water in swimming pools and spas.
2. They are designed to work with clean water at a temperature not exceeding 104°F (40°C)
3. The installation should be carried out in accordance to the safety instructions of swimming pools, especially Standard HD 384.7.702 , and the specific instructions for each facility.
4. The compulsory rules on accident prevention should be carefully followed.
5. Any modification of the pump requires the prior consent of the manufacturer. Original replacement parts and accessories authorized by the manufacturer ensure a high level of safety. The manufacturer of the pump assumes no liability for the damage and injuries caused by un-authorized replacement parts and accessories.
6. During operation, some parts of the pump are subject to dangerous electric voltage. Work may only be performed on each pump or on the equipment connected to it after disconnecting them from the main power and after disconnecting the starting device.
7. The user should make sure that assembly and maintenance tasks are carried out by qualified authorized persons and that these persons have first carefully read the instructions for service and installation.
8. The operating safety of the pump is only guaranteed if the installation and service instructions are correctly followed.
9. The limit values stated in the technical table should not be exceeded under any condition.

10. In the event of defective operation or fault, contact the technical support department of the manufacturer or it's nearest authorized agents.
11. If the supply cord is damaged, it must be replaced by the manufacturer or its service agent or a similarly qualified person to avoid a hazard.
12. The pump must not be used when people are in the water.
13. The pump must be supplied through a residual current device (RCD) having a rated residual operating current not exceeding 30mA.
14. Children should be under close supervision to prevent them from playing with the pump.
15. This appliance is not intended for use by persons (including children) with reduced physical, sensory or mental capabilities, or lack of experience and knowledge, unless they have been given supervision or instruction concerning use of the appliance by a person responsible for their safety.
16. The pump must be protected from running dry.

SAVE THIS INSTRUCTION MANUAL

Brief Introduction

This variable speed pump is designed to operate your swimming pool filtration system as well as your spa, waterfall, cleaner, heater, salt chlorine system and other water applications.

Using the control panel, you can run your pump on one of three scheduled programs:

1. **Regular mode:** use three quick start buttons. ECO (default 1500RPM)/CLEAN(default 2400RPM)/BOOST(default 3250RPM), and then adjust the pump to run at the your preferred.
2. **Mode 1:** 16 hours for each clean cycle.
3. **Mode 2:** 24 hours for each clean cycle.

The control panel also has LED indicators for speed as well as alarm indicator and error code to warn the user on the voltage problems, excessive temperature, over current and freeze protection etc.

1. Features of LED Control Panel

- (1) Display and change time.
- (2) Display and change running speed.
- (3) Quick-start button of ECO/CLEAN/BOOST to run on different speeds.
- (4) MODE1/MODE2 for scheduled programs (16 hours or 24 hours clean cycle).
- (5) Re-start and reset to normal schedule after over current, over voltage, over heat, or unexpected power off.
- (6) Keep records of scheduled programs for max 15 days after power off.
- (7) Run 5 minutes at high speed after the start
- (8) Step-by-step acceleration and deceleration of the speed to extend the use life of the motor and control panel

2. Introduction of LED Control Panel

Panel

- ① ECO: Press to select and run on default speed 1500RPM, can be adjusted from 1000 to 2400RPM
- ② CLEAN: Press to select and run on default speed 2400RPM, can be adjusted from 2400 to 2850RPM
- ③ BOOST: Press to select and run on default speed 3250RPM, can be adjusted from 2850 to 3450RPM

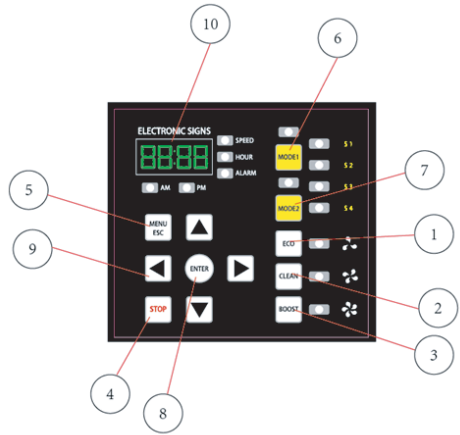

- ④ STOP: Press to stop the pump. And the screen displays the present time
- ⑤ MENU: Enter the pump menu if the pump is stopped
- ⑥ MODE 1: To run the programmed 16 hours clean cycle.
- ⑦ MODE 2: To run the programmed 24 hours clean cycle.
- ⑧ Enter: Save and exit the menu.
- ⑨ ARROW BUTTONS:
 - UP ARROW – Each press,moves up one level in the menu or to increase a digit when changing a setting
 - DOWN ARROW – Each press,moves one level down in the menu each press or to decrease a digit when changing a setting.
 - LEFT ARROW – Each press,moves the cursor left one digit when changing a setting
 - RIGHT ARROW – Each press,moves the cursor right one digit when changing a setting
- ⑩ LED Screen: Composed of four digital tubes. Display current time when standby. And display the current and running speed back and forth in operation.
- ⑪ AM/PM: Designed for 12-hour system. If pump run on 0:00-11:59, AM light on; if pump run on 12:00-23:59, PM light on.
- ⑫ MODE1 and MODE 2 have 4 stages, S1/S2/S3/S4 is the speed for each stage. If the S1 light is on, the pump is run on first stage, if the light twinkles, the time for the stage is not arrive yet or the pump is not running.
 - If SPEED light is on, the screen will display the current RPM
 - If HOUR light twinkles, you are ready to set the running time for each stage.
 - If ALARM light is on, an alarm condition exists.
- ⑬ Press MODE 1, the light will shine and one light of S1/S2/S3/S4 will be on or twinkle. (Light twinkle means the current time is not in the set running period), and one of AM or PM lights will be on.

- ⑭ Press MODE2, the light will shine and the one light of S1/S2/S3/S4 will be on or twinkle. (Light twinkle means the current time is not in the set running period), and one of AM or PM lights will on.
- ⑮ When the pump is in standby, switch MODE 1 and MODE2, the corresponding light will shine, and the pump run accordingly.

3. Stop And Run The Pump

3.1 Start The Pump

- 1) Make sure the pump is connected with power. When power is on, the display screen will display the time.
- 2) Press one of ECO/CLEAN/BOOST, the pump will run. The light on the corresponding program will shine. No matter what program you select, the pump will run on 2850RPM for 5 minutes to eliminate the air in the pump, so the impeller will not dry grind thus to cause leakage. After high-speed running, the pump will run the default speed of the selected program.

3.2 Stop The Pump

Press STOP, and the pump will stop. The lights on the screen twinkle.

3.3 Change Pump Running Speed

- 1) When the pump is running ECO/CLEAN/BOOST, press arrow buttons up or down to change the speed, each press will change for 50RPM. It will save automatically, no need to press ENTER.
- 2) Switch ECO/CLEAN/BOOST during pump operation, the pump will not run 5 minutes high speed again.
- 3) For MODE 1 and MODE 2, to change speed of S1 and S3, first press CLEAN, if not work, you will need to stop the pump first. After 5 minutes high speed running, press CLEAN, then press arrow button to increase or decrease RPM. When press MODE 1 or MODE 2 again to run the pump, S1 and S3 will run as just selected. To adjust S2 and S4, first press ECO, if not work, you will need to stop the pump. After 10 minutes high speed running, press ECO, then press arrow button to increase or decrease RPM. When press MODE 1 or MODE 2 again, S2 and S4 will run as just selected.

NOTE: RPM for S2 and S4 or S1 and S3 are always the same.

The default RPM for S1 and S3 is 2400RPM, the adjustable range is 2400 to 2850RPM.

The default RPM for S2 and S4 is 1500RPM. The adjustable range is 1000 to 2400RPM.

3.4 Pump Run Under Pre-programmed Conditions

Pump has three quick start buttons ECO/CLEAN/BOOST, as below figure. The default speeds are 1500, 2400, 3250RPM respectively.

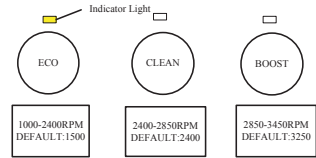

- 1) Be sure the pump is power on.
- 2) Press one of ECO/CLEAN/BOOST buttons, the LED light on screen will shine.
- 3) The screen will display STUP (means Start Up) for 1 second, and run 2850RPM for 5 minutes.

After 5 minutes, the pump will run on the selected speed.

4. Pump Run Under MODE1/MODE2

4.1 MODE 1/MODE2 Introduction

MODE 1					MODE 2				
16 hours running cycle					24 hours running cycle				
Stage	Start Time	Running Hour	Default Speed	Quick Start Button	Stage	Start Time	Running Hour	Default Speed	Quick Start Button
S1	6:00 AM	3 (adjustable)	2400RPM (adjustable)	CLEAN	S1	12:00 PM	6 (adjustable)	1500RPM (adjustable)	ECO
S2	9:00 AM	5 (adjustable)	1500RPM (adjustable)	ECO	S2	6:00 AM	3 (adjustable)	2400RPM (adjustable)	CLEAN
S3	6:00 PM	3 (adjustable)	2400RPM (adjustable)	CLEAN	S3	9:00 AM	9 (adjustable)	1500RPM (adjustable)	ECO
S4	9:00 PM	5 (adjustable)	1500RPM (adjustable)	ECO	S4	6:00 PM	6 (adjustable)	2400RPM (adjustable)	CLEAN

4.2 How to Set and Change Specification of MODE1/MODE2

- 1) Make sure STOP button is pressed before set up, and pump is not working. Press MENU, LED screen will display the current time (time will not count during set-up), use arrow buttons to adjust the time. LEFT and RIGHT to move the cursor one digit, and UP and DOWN to increase or decrease one digit. (Remarks: 0:00-11:59 is one cycle). For example, the current time is 6:00 and AM light is shining, when change the time after 11:59, the time change to 0:00, PM light will shine.
- 2) After time set-up, press ENTER to save and quit. Don't press ENTER if you would like to continue to change the specification of

MODE1 and MODE 2. Press MENU again, the light of MODE 1 and S1 will shine, screen display 6:00, and AM light is shine. Use arrow buttons to adjust the time. When the time is over 11:59, PM light will shine, AM light extinguished.

- 3) Press ENTER to save and quit after start time set-up. To continue and adjust the running hour, press MENU, then use arrow buttons to increase and decrease running hours. Each press is for 1 hour. Press ENTER to save and quit. Or press MENU to adjust S2/S3/S4, the same adjustment method as S1.
- 4) Follow MODE 1's adjustment methods to adjust MODE 2.
- 5) **Could not change speed using arrow buttons when running**

MODE1/MODE2. Can only change the speed of MODE 1 and MODE 2 by pressing CLEAN/ECO/BOOST, and then use arrow button UP and DOWN to change the RPM. When it is done, the corresponding speed in MODE 1/MODE 2 will also be changed.

You could do the changes in the right categories. For example, in MODE 1, S1 and S3 is CLEAN, S2 and S4 is ECO; in MODE 2, S1 and S3 is ECO, S2 and S4 is CLEAN.

5. How to Operate The Pump?

Totally three pre-programmed schedules: Regular Mode (including ECO; CLEAN; BOOST) and MODE 1/MODE 2.

Can change the speed in the mode of ECO/CLEAN/BOOST freely.

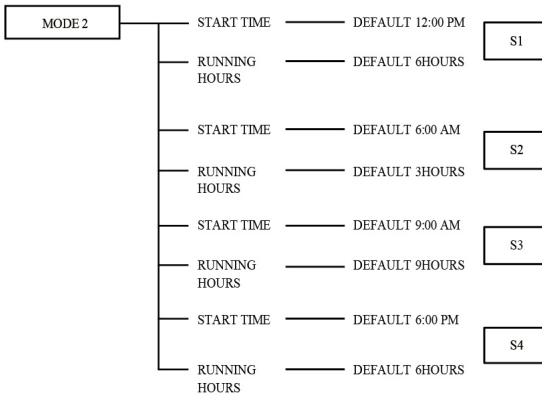
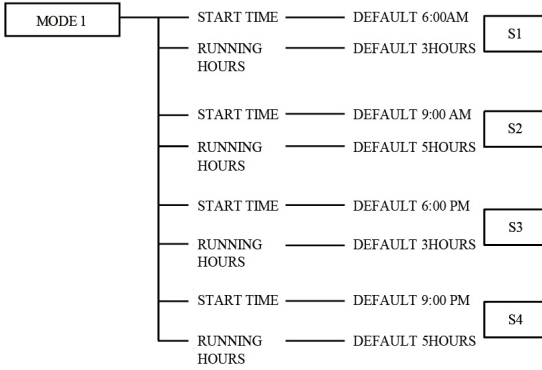
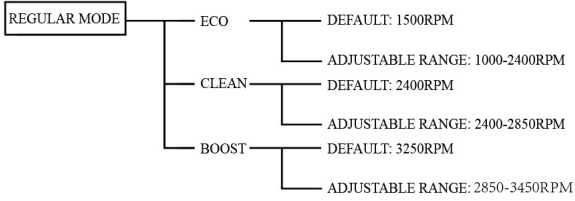

6. Control Panel Menu Structure

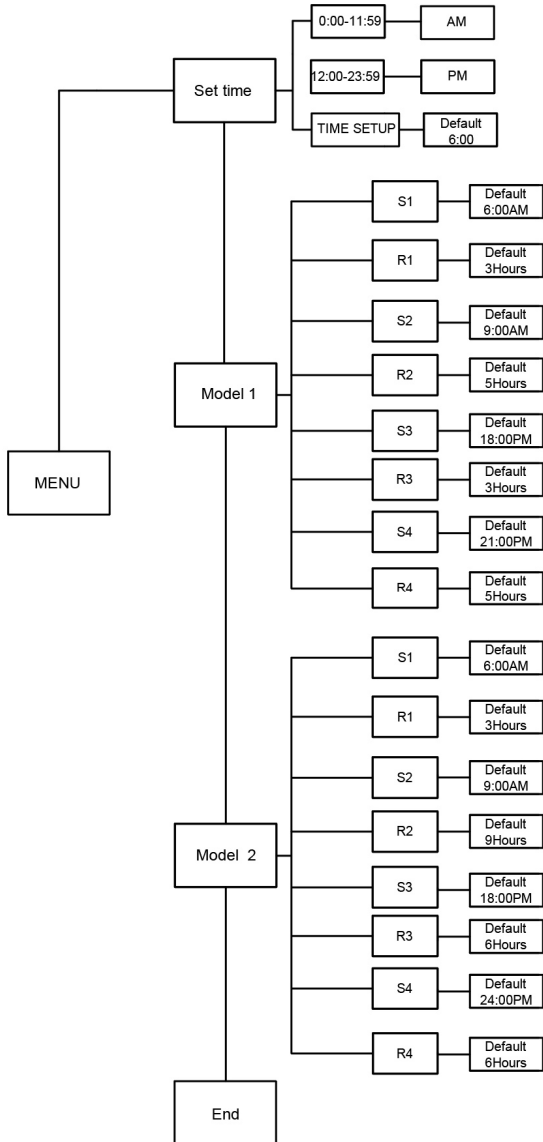

7. Parts Breakdown

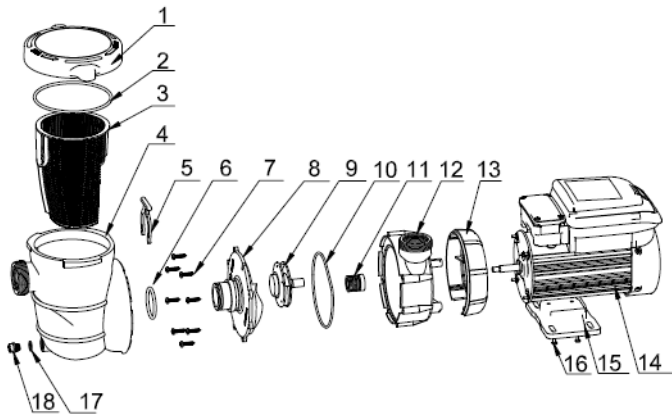

1	647252772000	Strainer Cover	1
2	5431042080	Strainer Cover O-Ring	1
3	47252704001	Basket	1
4	47252703080	Strainer Housing	1
5	47252705080	Clip	1
6	5431029080	Strainer Housing O-Ring	1
7	5212016000	Screw ST5.5*25	8
8	47252702080	Diffuser	1
9	64727297130	Impeller	1
10	5431040080	Housing O-Ring	1
11	5028003000	Seal Assembly	1
12	47252701080	Pump Housing	1
13	47252708080	Motor Mounting Plate	1
14	5023410000	Motor	1
15	41038005	Mounting Foot	1
16	5224025000	Screw M5*14	4
17	5432002080	O-Ring	1
18	48860105080	Drain Plug	1

8. Performance Curve

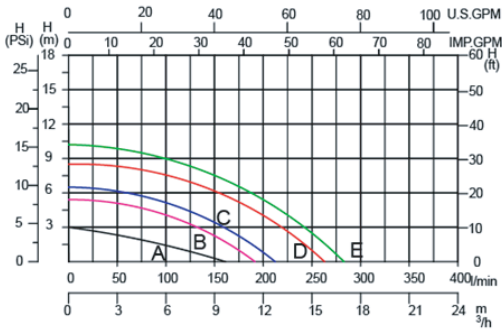

品号	曲线
2000	A
2400	B
2850	C
3250	D
3450	E

9.Alert and Warnings

The pump displays all alerts and warnings on the control panel. When an alarm or warning condition exists, the corresponding LED will shine and the error code will be displayed on the screen. All control panel buttons are disabled until the alarm or warning is acknowledged by press the ENTER button. Power off until the display off.

Alert code details:

Code	Error	Remarks
1	Locked rotor, short circuit of motor wire or excessive temperature rise of the driver	
2	Input voltage is too high	
4		
6		
8	Input voltage is too low	When the power is turned off, the pump still can work for a while as the remaining electricity in its energy storage elements, and then the alarm code 8 will be displayed, which is normal. At this time, if you want to restart, please wait until the screen is off.
32	The motor has not been started normally	
64	Motor phase-break	
4003	No-load	Priming problem
16	system error	Please turn off the water pump, wait for the panel indicator to go out completely, restart
128		

256		the water pump and observe the error. Please contact the supplier,if the error is still exist.
512		
1024		
0		
4001		
4002		
4096		

After power off, it will takes more than ten seconds to restart, as the internal energy storage elements need to be discharged. The pump may work abnormally,if the circuit board is restarted before the power is discharged. If it occurs, power off and wait for a while to power on again

