

# ***Doheny's***

**Pool Supplies FAST!**

# **Pool Pro Ultra AG**

Item #s 90700 & 90701

## **INSTALLATION, OPERATION & PARTS**

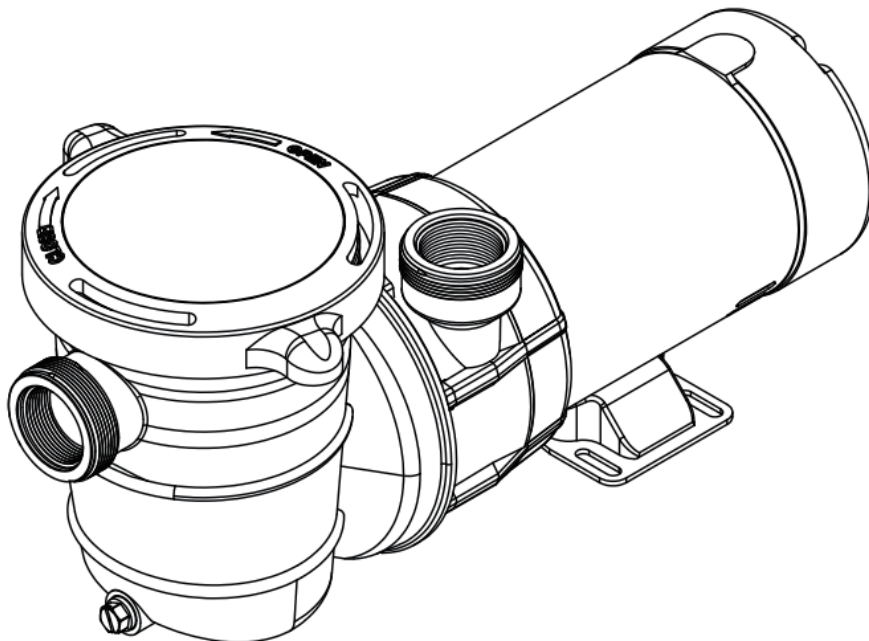

### **! WARNING**

This equipment must be installed and serviced by a qualified technician or professional, in accordance with the National Electrical Code and all applicable local codes and Ordinances. Improper installation can create electrical hazards which could result in property damage, serious injury or death. Improper installation will void the warranty.

### **Notice to Installer**

This manual contains important information about the installation, operation and safe use of this product. Once the product has been installed this manual must be given to the owner/ operator of this equipment.



Water temperature in excess of 100° F (37.7° C) may be hazardous to your health. Prolonged immersion in hot water may induce hyperthermia. Hyperthermia occurs when the internal temperature of the body reaches a level several degrees above normal body temperature of 98.6° F (37° C.). Effects of hyperthermia include: (1) Unawareness of impending danger. (2) Failure to perceive heat. (3) Failure to recognize the need to leave the spa. (4) Physical inability to exit the spa. (5) Fetal damage in pregnant women. (6) Unconsciousness resulting in danger of drowning. The use of alcohol, drugs, or medication can greatly increase the risk of fatal hyperthermia in hot tubs and spas.



To reduce the risk of injury, do not permit children to use or operate this equipment.



When setting up pool water turnovers or flow rates, the operator must consider local codes governing turnover as well as disinfectant feed ratios.



If this pump is intended for use in other than single-family dwellings, a clearly labeled emergency switch shall be provided as part of the installation. The switch shall be readily accessible to the occupants and shall be installed at least 5 feet (1.52 m) away, adjacent to and within sight of this pump.

#### RISK OF ELECTRICAL SHOCK OR ELECTROCUTION:



**PUMPS REQUIRE HIGH VOLTAGE WHICH CAN SHOCK, BURN, OR CAUSE DEATH.** Before working on pump, always disconnect power to the pool pump at the circuit breaker before servicing the pump. Failure to do so could result in death or serious injury to service person, pool users or others due to electric shock.



Pumps improperly sized or installed or used in applications other than for which the pump was intended can result in serious personal injury or death. These risks may include but not be limited to electric shock, fire, flooding, suction entrapment or serious injury or property damage caused by a structural failure of the pump or other system component.



Never exceed the maximum stated pump flow rating. Only use a pumping system rated for the corresponding flow. **FAILURE TO DO SO CAN RESULT IN HAIR OR BODY ENTRAPMENT WHICH CAN CAUSE SERIOUS PERSONAL INJURY OR DEATH.** If in doubt about the rating of your system, consult a qualified pool service professional.



Pumps are not a substitute for properly installed and secured pool drain covers. An ANSI/ASME A112.19.8 approved anti-entrapment drain cover must be used for each drain. Pools and spas should utilize a minimum of two drains per pump. Regularly inspect all covers for cracks, damage and advanced weathering. If a cover becomes loose, cracked, damaged, broken or is missing, close the pool or spa immediately, shut off the pump, post a notice and keep the pool or spa closed until an appropriate VGB 2008 certified cover is properly installed. Covers deteriorate over time due to exposure to sunlight and pool chemicals. This cover must be replaced within seven (7) years from installation (or earlier if the cover becomes damaged in any way).

# WARNINGS AND IMPORTANT SAFETY PRECAUTIONS

## **DANGER** SUCTION ENTRAPMENT HAZARD



**Hair Entanglement** – When the hair tangles or knots in the drain cover, trapping the swimmer underwater. This hazard is present when the flow rating of the cover is too small for the pump or pumps.

**Limb Entrapment** – When a limb is sucked or inserted into an opening resulting in a mechanical bind or swelling. This hazard is present when a drain cover is missing, broken, loose, cracked or not properly secured.

**Body Entrapment** – When a portion of the body is held against the drain cover trapping the swimmer underwater. This hazard is present when the drain cover is missing, broken or the cover flow rating is not high enough for the pump or pumps.

**Evisceration/Disembowelment** – When a person sits on an open pool (particularly a child wading pool) or spa outlet and suction is applied directly to the intestines, causing severe intestinal damage. This hazard is present when the drain cover is missing, loose, cracked, or not properly secured.

**Mechanical Entrapment** – When jewelry, swimsuit, hair decorations, finger, toe or knuckle is caught in an opening of an outlet or drain cover. This hazard is present when the drain cover is missing, broken, loose, cracked, or not properly secured.

## GENERAL SAFETY RULES

1. The products mentioned in this manual are specially designed for the pre-filtering and re-circulation of water in swimming pools and spas.
2. They are designed to work with clean water at a temperature not exceeding 104°F (40°C)
3. The installation should be carried out in accordance to the safety instructions of swimming pools, especially Standard HD 384.7.702 , and the specific instructions for each facility.
4. The compulsory rules on accident prevention should be carefully followed.
5. Any modification of the pump requires the prior consent of the manufacturer. Original replacement parts and accessories authorized by the manufacturer ensure a high level of safety. The manufacturer of the pump assumes no liability for the damage and injuries caused by un-authorized replacement parts and accessories.
6. During operation, some parts of the pump are subject to dangerous electric voltage. Work may only be performed on each pump or on the equipment connected to it after disconnecting them from the main power and after disconnecting the starting device.
7. The user should make sure that assembly and maintenance tasks are carried out by qualified authorized persons and that these persons have first carefully read the instructions for service and installation.
8. The operating safety of the pump is only guaranteed if the installation and service

instructions are correctly followed.

9. The limit values stated in the technical table should not be exceeded under any condition.

10. In the event of defective operation or fault, contact the technical support department of the manufacturer or its nearest authorized agents.

11. If the supply cord is damaged, it must be replaced by the manufacturer or its service agent or a similarly qualified person to avoid a hazard.

12. The pump must not be used when people are in the water.

13. The pump must be supplied through a residual current device (RCD) having a rated residual operating current not exceeding 30mA.

14. Children should be under close supervision to prevent them from playing with the pump.

15. This appliance is not intended for use by persons (including children) with reduced physical, sensory or mental capabilities, or lack of experience and knowledge, unless they have been given supervision or instruction concerning use of the appliance by a person responsible for their safety.

16. The pump must be protected from running dry.

## SIZE

72808:

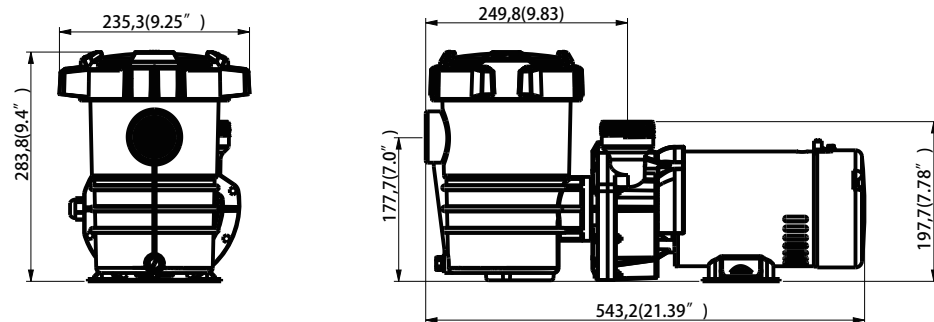

72809:

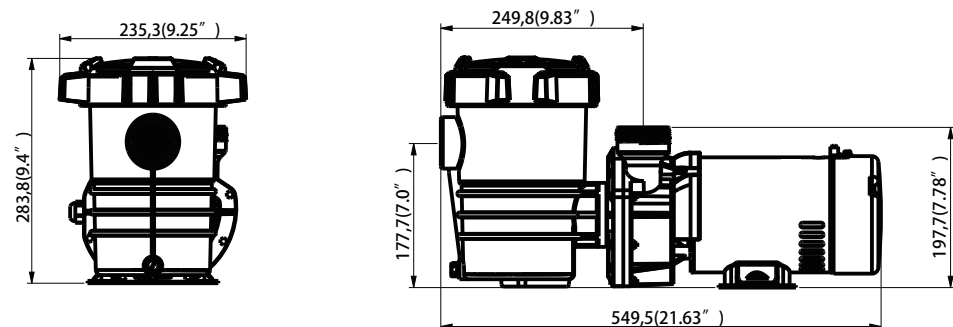

## INSTALLATION

A few simple precautions during installations will ensure years of trouble free operation.

1. The pump suction line should not be smaller than 1 1/2" (40mm imperial) or 50mm true metric.

2. The suction line is to have as few bends or elbows as possible. There must not be an air traps on the suction line.

3. Installation shall arrange on a solid, flat foundation with the pump bolted securely to it.

4. The pump electrical cable must be wired for the proper voltage and current in accordance with the wiring instructions.

5. All wiring (electrical) work must be carried out by licensed electricians and must be installed in accordance to the local codes.

6. The motor must be grounded.

7. The weight of the plumbings and fittings is to be independently supported and not carried by the pump.
8. The maximum total head (Hmax) of the pump (in metres) shown on the pump label should be noted by the installer.
9. The permissible temperature is  $> 32^{\circ}\text{F}$  ( $0^{\circ}\text{C}$ ) and  $< 104$  ( $40^{\circ}\text{C}$ ). The pump should never be operated outside of these temperatures, or damage may occur.

### **Important Electrical Notice**

**The electrical installation is to be done by a licensed electrician.**

Each pump requires a circuit breaker to separate the pump from the electrical supply.

The open contact distance of the circuit breaker is to be no less than 3mm

The pump is to be supplied by an isolating transformer, or supplied through a residual current device (RCD) with a rated residual current not exceeding 30mA.

Check the pumps name plate for the following: Voltage, Amp draw and Cycle.

The power cord, including the ground wire shall have a quality of 245 IEC66 (HO7RN-F) for models greater than 1kW power input.

For models less than 1kW input the quality shall be of 245 IEC57 (H05RN-F).

All installations must comply with local codes, based on IEC 364-7-702 requirements.

**RESPECT THE MINIMUM GAUGE GIVEN IN THE CHART OF THE TECHNICAL MANUAL.**

### **ELECTRICAL CONNECTION**

Check that the information on the nameplate corresponds to the power supply.

Employ a competent electrician to ensure wiring installation is made in accordance with any local electrical codes. Every motor requires either a fused disconnect switch or a circuit breaker.

A SINGLE PHASE MOTOR has a built in thermal overload switch.

### **Priming**

The pump will prime and pre-prime providing the filter tank water and there is sufficient supply from the suction point.

**If you lose water from the filter tank it will be necessary to re-fill it before starting.**

1. Remove the translucent lid and fill the filter tank with water.
2. Replace the lid ensuring the o-ring is correctly located and start the pump.

After you have done this allow a few minutes (maximum) running for the pump to start delivering water.



High suction lift or long suction lines will require additional time to prime and can severely affect the performance of the pump. If the pump does not prime, please repeat step 1 and 2 above. Mechanical seals if running dry can be damaged rapidly and may need to be replaced. ENSURE that there is always adequate water in the filter tank before you start up. If you are unable to prime the pump please see the trouble-shooting guide.

ENSURE that all suction and discharge valves are open before you start the pump, otherwise will result in damage to the pump.

## Maintenance

The strainer basket in the filter tank should be inspected and cleaned at regular intervals.

1. Remove lid and lift out basket.
2. Remove debris and hose off with clean water if necessary.
3. Inspect the lid gasket, lubricate with silicon based grease only if needed. If it is damaged, pls replace.
4. Replace the strainer.
5. Re-prime the filter tank.
6. Correctly locate the o-ring.
7. Replace the lid hand tighten only.
8. Switch on pump.

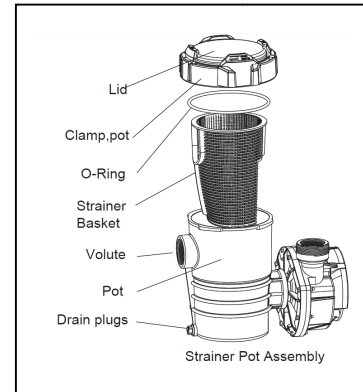

In climates where the pump may be exposed to frost or freezing, care must be taken to ensure the pump is protected from damage. It is recommended that if the pump is not used during winter period it should be drained completely and store pump in a dry location. Do not replace the drain plug. Store it in a safe place when not use. An example would be store plug in the filter tank basket.

When you are activate the pump ensure all seals and o-rings are in operational condition, re-grease if necessary, replace if unsure of condition.

Check that the motor shaft moves freely before re-activation.

### **WARNING**

1. When connecting electric cables to the motor of the pump, be careful to correctly arrange them inside the connection box, verify that no bits of cable are left inside the box on closing it. See that the ground wire is correctly connected. When connecting the motor, follow the wiring diagram supplied with the pump.
2. Be especially careful that no water enters the motor or electrical parts under voltage.
3. In the event that the planned use is not as specified, adaptations and supplementary technical rules may be necessary.
4. Before starting the pump, verify the calibration of the electrical protection devices of the motor and that the protections against electrical and mechanical contacts are correctly positioned and attached.
5. It is advisable to follow the steps listed below before handling the pump in any way.
  - a) Turn off the voltage to the pump.
  - b) Lock starting devices.
  - c) Verify that there is no voltage in the circuits, including ancillary devices and auxiliary circuits.
  - d) Wait until motor stops completely.

The above list should be considered indicative and not binding for the purpose of safety, specific safety rules may exist in particular regulations.

## Assembly Instructions (some parts may be pre-assembled)

Follow the step below and the corresponding diagrams for assembly.

### Step 1.

Place the strainer basket to the strainer housing. Be sure that the opening the basket is aligned with the opening in the housing. Secure Lid

## Step 2.

The water level of the inground swimming pool is lower than the water inlet of the pump. In order to prevent water from flowing backward, this pump equipped a check valve. First screw the adaptor into the water inlet of the pump, and then install the connector assembly.

### Step 1

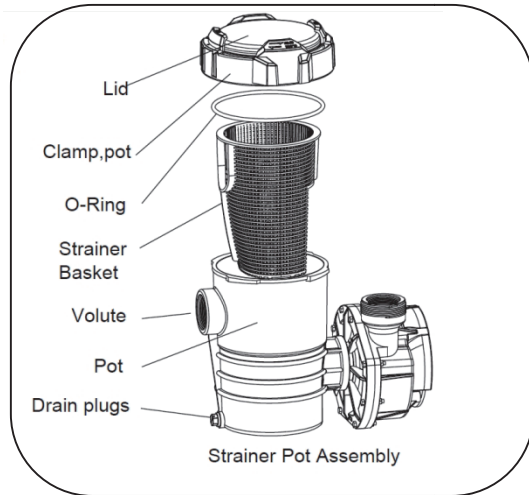

### Step 2

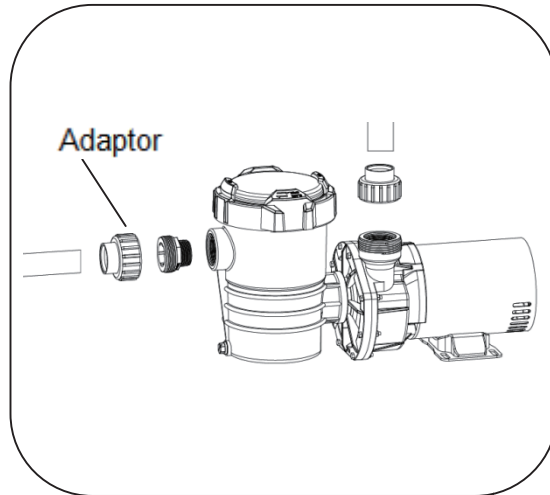

## REGULARLY VERIFY

1. The correct attachments of the mechanical parts and of the support screws of the pump.
2. The correct position, attachment and condition of the supply cables and of the insulating parts.
3. The temperature of the motor. In the event of any excessive high, stop immediately and have it repaired.
4. The vibration of the pump. In the case of any excessive high, stop immediately and have it repaired.

## CAUTION

Owing to the complexity of the cases covered, the instructions for installation, use and maintenance contained in this manual do not attempt to examine all possible and imaginable cases of service and maintenance. If supplementary instructions are required or special problems arise, do not hesitate to contact the distributor/agent.

## TECHNICAL DATA

Item	90700	90701
Input Power	840W	1030W
H. Max	10.1M	12.1M
Q. Max/min	320L/min(84.5GPM)	365L/min(96.3GPM)
V	115V	115V
HZ	60	60
IP	IPX5	IPX5



## ILLUSTRATED PARTS LIST

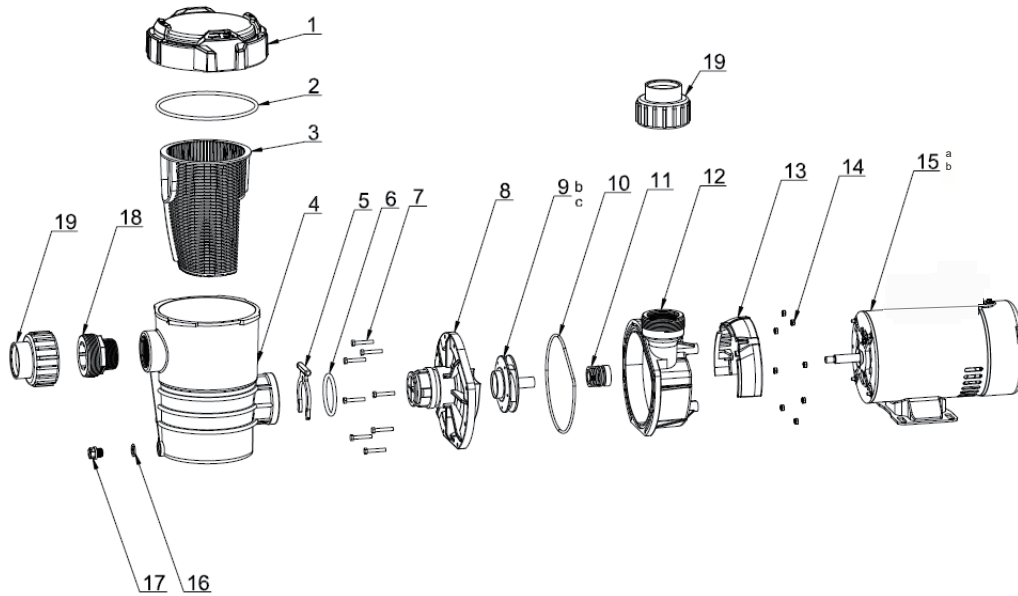

Ref.No.	Part. No.	Description	QTY	Remark
1	47284805080	Cover	1	
2	5421042080	O-Ring	1	
3	47252718001	Basket	1	
4	47284801080	Pump Housing	1	
5	47252705080	Clip	1	
6	5431029080	O-Ring	1	
7	5221002000	Screw M5*30	8	
8	47284802080	Pump Cover	1	
9a	647272971000	Impeller For 90700	1	
9b	647252771000	Impeller For 90701	1	
9c				
10	5431044080	O-Ring	1	
11	5028003000	Seal Assembly	1	
12	47284803080	Pump Housing	1	
13	47284804080	Motor Mounting Plate	1	
14	5231016106	Nut M5	8	
15a	5023452000	1.0HP Motor For 90700	1	
15b	5023453000	1.5HP Motor For 90701	1	
16	5432002080	Drain Plug Gasket	1	
17	48860105080	Drain Plug	1	
18	47202702080	Adaptor	1	
19	49138201080	1.5" Adaptor Assembly	2	



## TROUBLESHOOTING

Problem	Cause	Solution
Low flow	Dirty filter	Backwash or clean cartridge
	Dirty skimmer and pump strainer	Clean skimmer and pump strainer
	Suction air leak	Make sure water level is correct through suction points. Ensure baskets and strainers are free of debris. Tighten all fittings/unions on the suction side of the pump, remove and replace mechanical seal
	Closed valve or blocked line	Make sure water level is correct through suction points. Ensure baskets and strainers are free of debris. Tighten all fittings/unions on the suction side of the pump, remove and replace mechanical seal
Pump does not run	Not plugged in	Check the socket and power cord
	GFCI/or main circuit breaker tripped	Switch on the breaker. If it is immediately tripped again, There is a defect in pump or controls.
	Faulty Pump shaft /motor	Replace the pump/motor assembly.
	Pump shaft is locked	Check if the pump can be rotated by hand and remove any blockage
Pump will not prime	Suction air leak	Make sure water level is correct through suction points. Ensure baskets and strainers are free of debris. Tighten all fittings/unions on the suction side of the pump, remove and replace mechanical seal
	No water in the pump	Make sure the filter tank is full
	Closed valves or blocked lines	Open all valves in the system, clean skimmer and pump basket, check pump impeller of blockage
Motor overload cuts out	Motor not connected properly	Have electrician check wiring
	Low incoming voltage	Voltage at motors should be no more than 6% above or below nameplate voltage. Have electrician check voltage; ensure pump is not running on an extension cord. Report low supplier to authorities.
	Overload due to binding in pump or wrong size impeller	Contact supplier

Noise pump operation	Bad bearing	Have electrician replace
	Air leak in suction	Make sure water level is correct through suction points. Ensure baskets and strainers are free of debris. Tighten all fittings/unions on the suction side of the pump, remove and replace mechanical seal
	Suction blockage	Locate and clean blockage
	Disturbance in impeller	Contact supplier
	Cavitations	Improve suction, reduce suction lift, reduce number of fittings, increase pipe size, increase discharge pressure and reduce flow by throttling discharge valve
Motor runs hot	Low or incorrect voltage	Supply to be corrected by electrician. A motor running hot to touch is normal. Thermal overload protector will function to turn them off if there is an overload or excessive high temperature problem
	Installed in direct sunlight	Shield from weather
	Poor ventilation	Do not tightly cover or enclose motor



If the pump is within the stated warranty period and you experience faults always contact your supplier. Failure to do this may void warranty. Refer to warranty documentation supplied with pump. All electrical work is to be carried out by a Qualified Electrician; under no circumstances should you attempt repairs on the electrical components of pumps unless you are qualified to do so.